

G1 PLUS SERIES DOOR PROJECTION MOUNTED INSTALLATION INSTRUCTIONS

READ THIS MANUAL CAREFULLY. OBSERVE WARNINGS AND PRACTICE CAUTION WHEN INSTALLING, OPERATING, OR MAINTAINING YOUR GOFF'S DOOR ASSEMBLY.

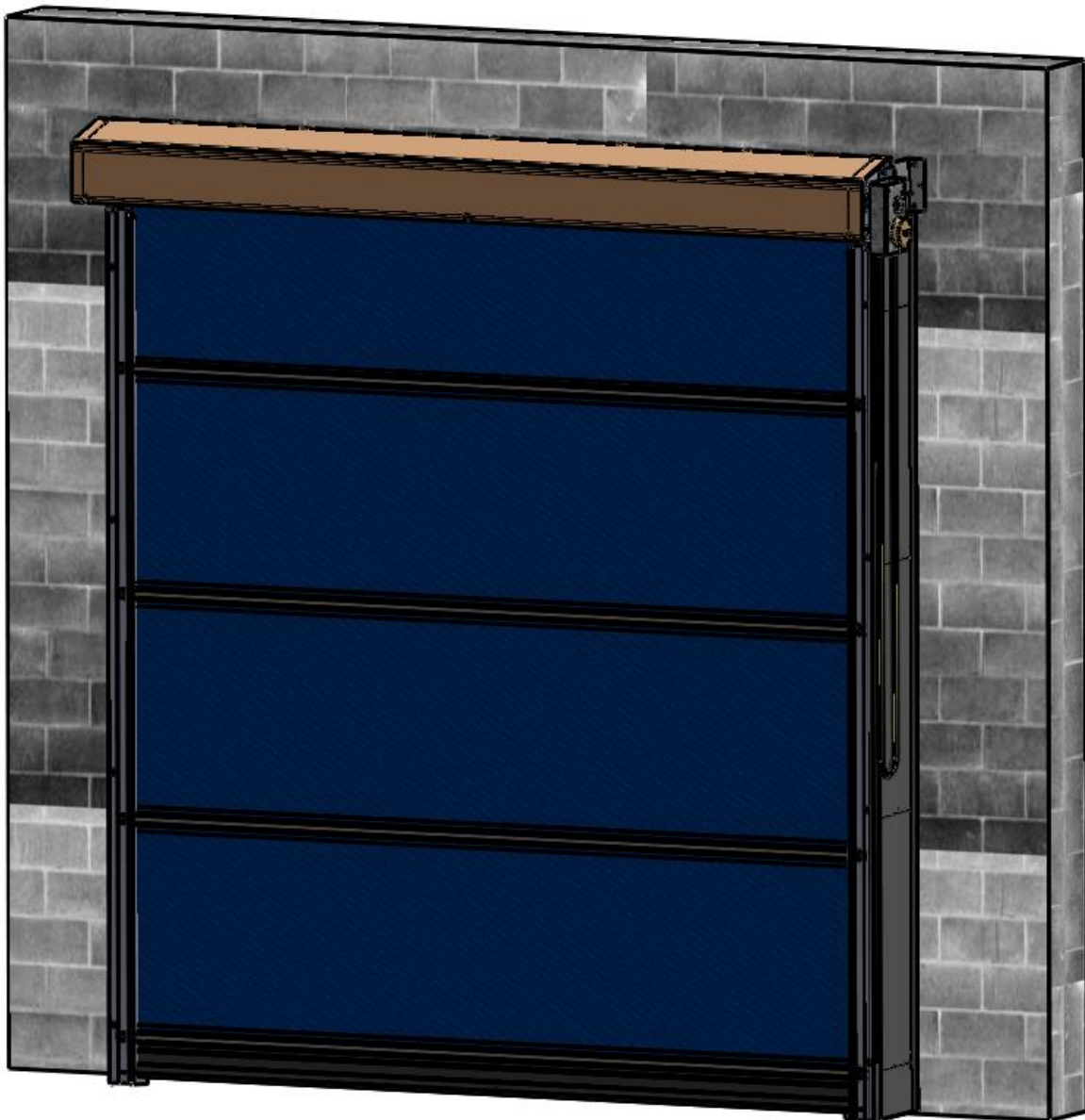

PREPARE MOUNTING SURFACE AND SECURE HEADER OFFSET BRACKETS

1. Measure the existing door width at the opening or frame from the outermost edges on each side near the top of the opening. Divide that overall width measurement in half to find and clearly mark the center of the top of the door frame or its header. (Figure 1 MEASURE/MARK OPENING)
2. Place the G1 Door roll Header Assembly across a safe and level work surface, and rotate the roll assembly frame so that the Header Bracket Mounting flanges are facing upward. (Figure 2 MEASURE DOOR WIDTH).
3. Measure the total width of the whole roll assembly from outermost edge of one Header Bracket's Mounting flange to the outermost edge of the opposite side. (Figure 2 MEASURE DOOR WIDTH)
4. Divide that number by 2, and measure to each side of the center mark in step 1. Mark a vertical line at these locations. This is where the outer edges of the Header Bracket's Mounting flanges will be. (Figure 3 MARK DOOR WIDTH ON WALL)
5. Set one of the Vertical Track Assemblies on your work surface and measure the length of the vinyl Track only. ADD 3-1/4" to this number and take note. This is the height dimension needed to mark the location of the bottom edge of the Header Mounting Brackets. With this number, add a horizontal line on each side of the opening that intersects the previously drawn vertical line marking the overall width of the roll assembly. (Figure 4 MEASURE TRACK HEIGHT) (Figure 5 MARK TRACK HEIGHT)

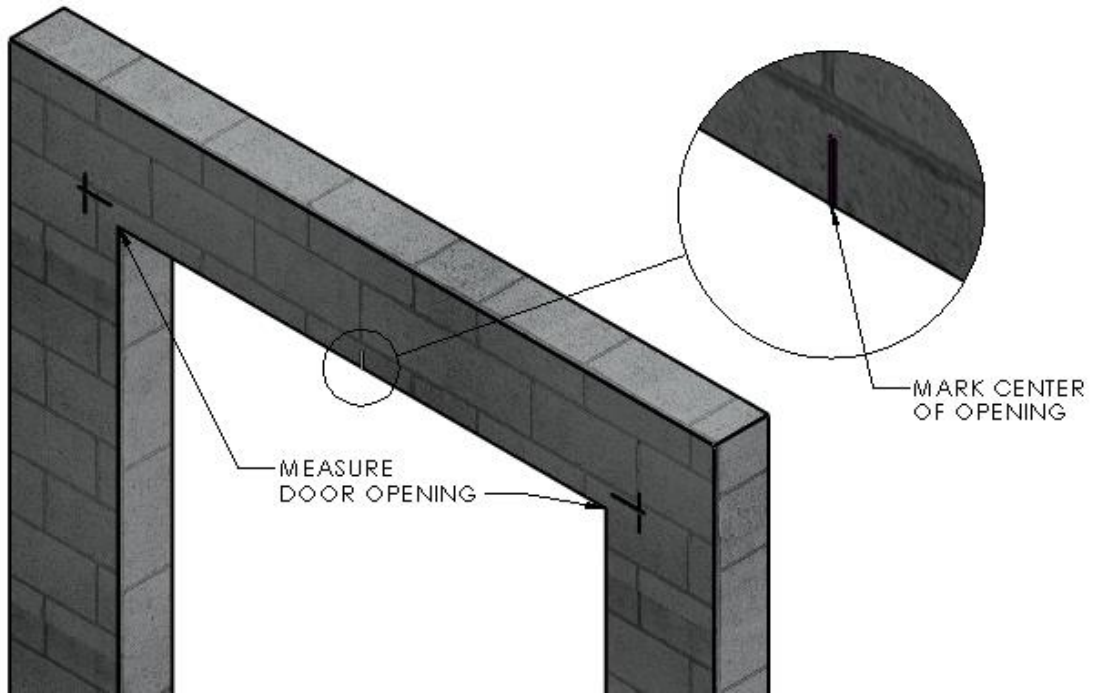

Figure 1 MEASURE/MARK OPENING

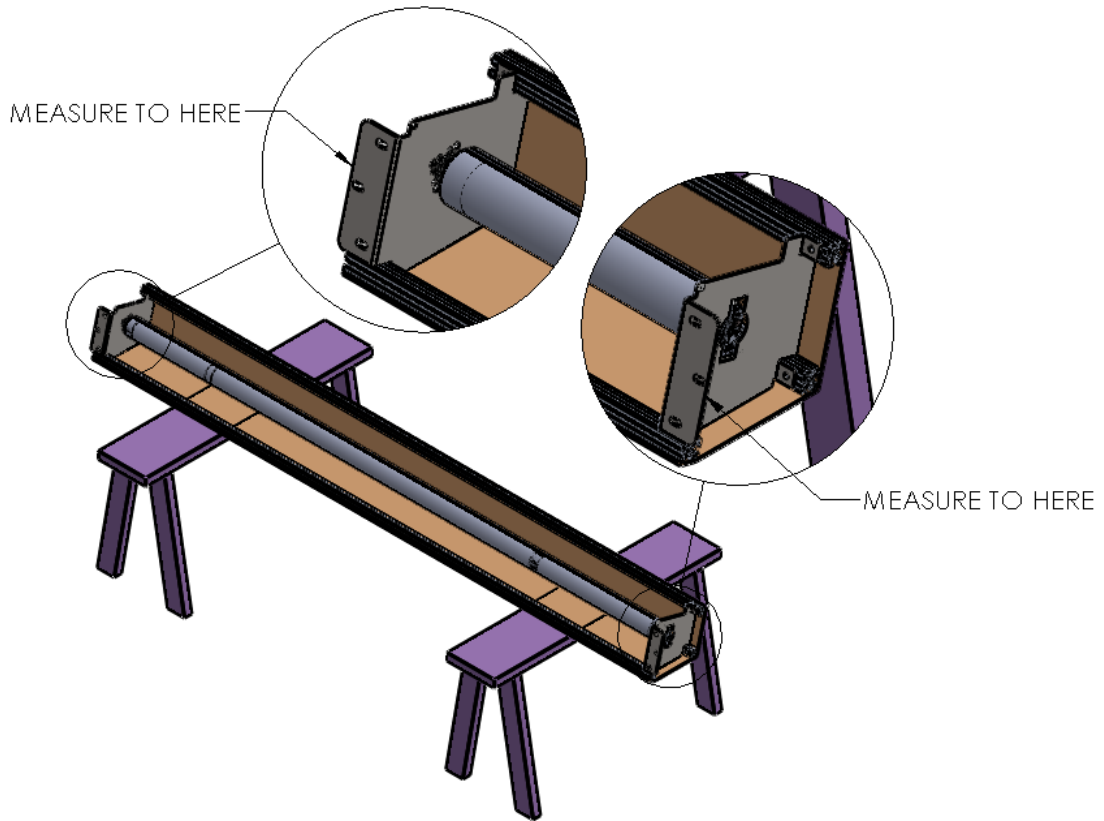

Figure 2 MEASURE DOOR WIDTH

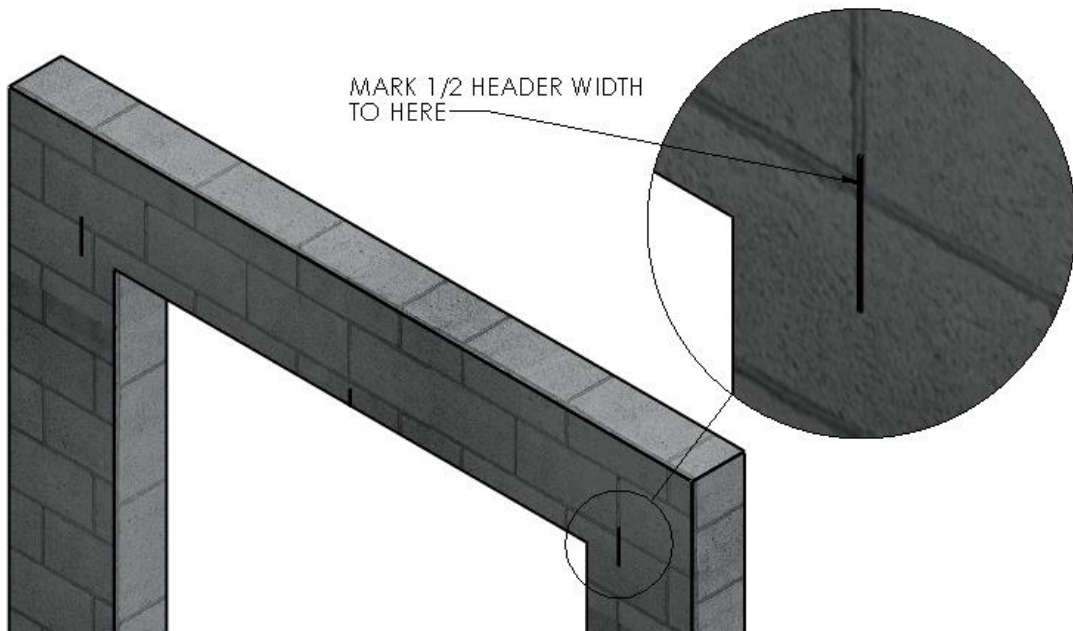

Figure 3 MARK DOOR WIDTH ON WALL

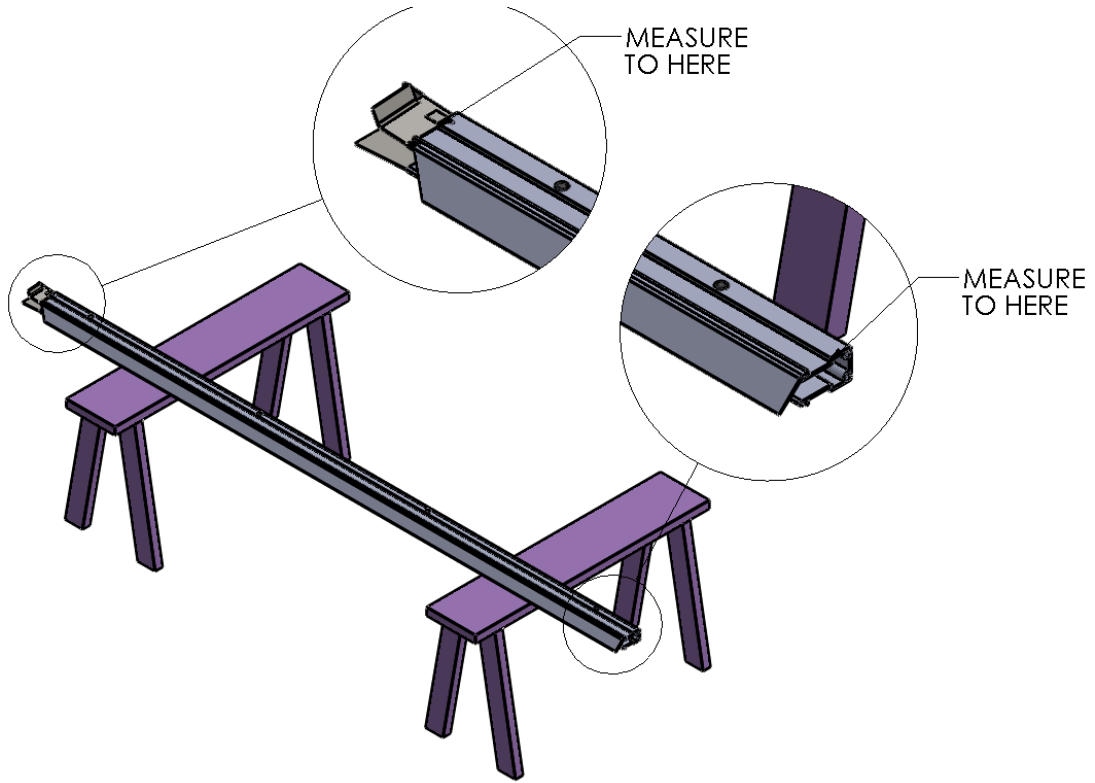

Figure 4 MEASURE TRACK HEIGHT

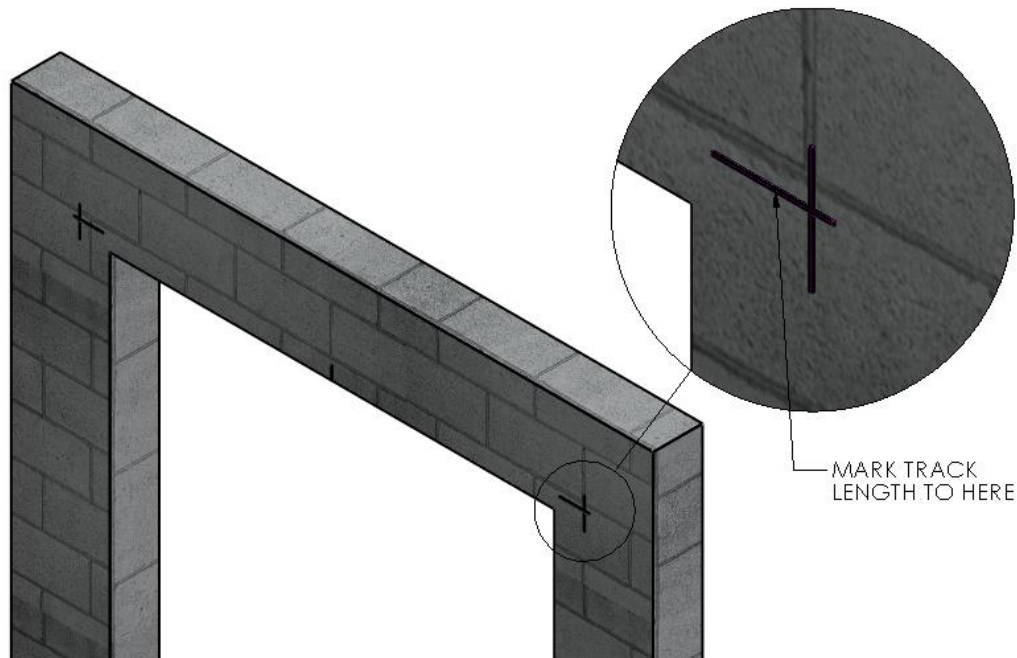

Figure 5 MARK TRACK HEIGHT

G1XL SERIES – PROJECTION MOUNTING INSTALLATION INSTRUCTIONS

READ THIS MANUAL CAREFULLY. OBSERVE WARNINGS AND PRACTICE CAUTION WHEN INSTALLING, OPERATING, OR MAINTAINING YOUR GOFF'S DOOR ASSEMBLY.

PREPARE PROJECTION BRACKETS

1. Find two packages of Projection Mount Brackets, and a bag with screws, nuts and Velcro strips. (Figure 6 PROJECTION BRACKET PACKAGE)
2. Locate two (2) Header Brackets and measure to the outer edges. Note this dimension for the next step. (Figure 7 HEADER BRACKET)
3. Assemble (8) eight Track Bracket assemblies to the same dimension as the Header Brackets by measuring to the outer edges of the brackets and installing (2) two sets of ¼-20 screws and nuts, provided, through corresponding holes. Set these Brackets aside for now. (Figure 8 TRACK BRACKET ASSEMBLY, Figure 9 COMPLETED TRACK BRACKET ASSEMBLY (8 Req'd))

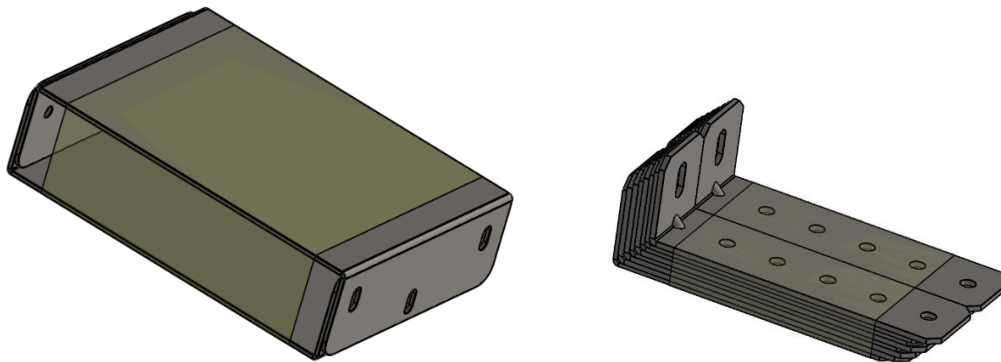

Figure 6 PROJECTION BRACKET PACKAGES

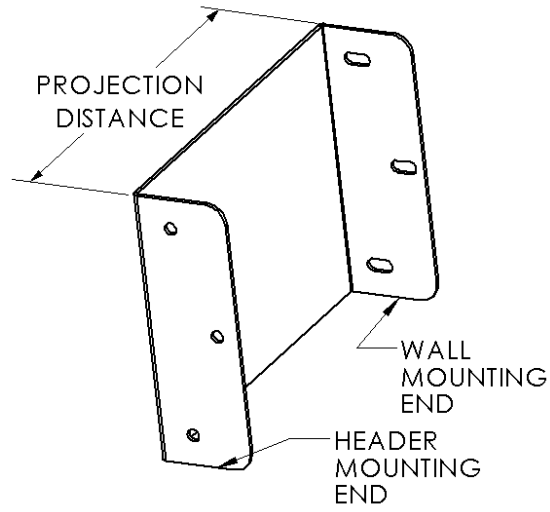

Figure 7 HEADER BRACKET

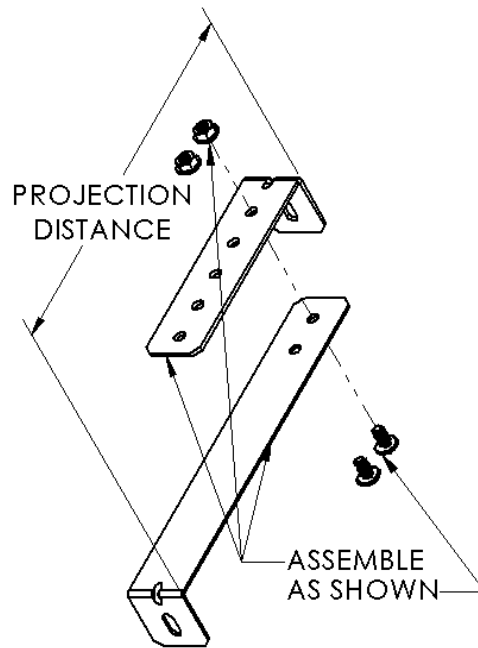

Figure 8 TRACK BRACKET ASSEMBLY

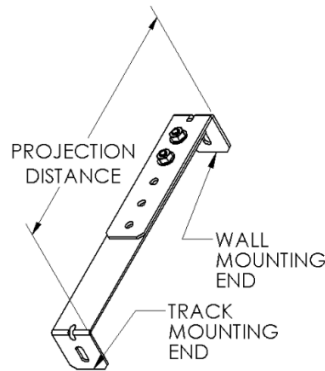

Figure 9 COMPLETED TRACK BRACKET ASSEMBLY (8 Req'd)

INSTALL HEADER PROJECTION BRACKETS

1. Using the wall end of one of the Header Projection Mount Brackets, trace the insides of its oval mounting slots onto the wall mount surface (a Sharpe permanent marker works great for this). Be sure that its flange is facing outward, that its bottom edge is on the height line, and that the outer edge is on your vertical overall width line. (Figure 10 LOCATE/INSTALL HEADER OFFSET MOUNTING BRACKET)
2. Pre-drill through the centers of the traced locations for the mounting hardware, three (3) pilot holes on each side. Using adequate mounting screws or bolts (depending on your building/surface material) attach the header offset brackets to each side of the opening. (Figure 10 LOCATE/INSTALL HEADER OFFSET MOUNTING BRACKET)

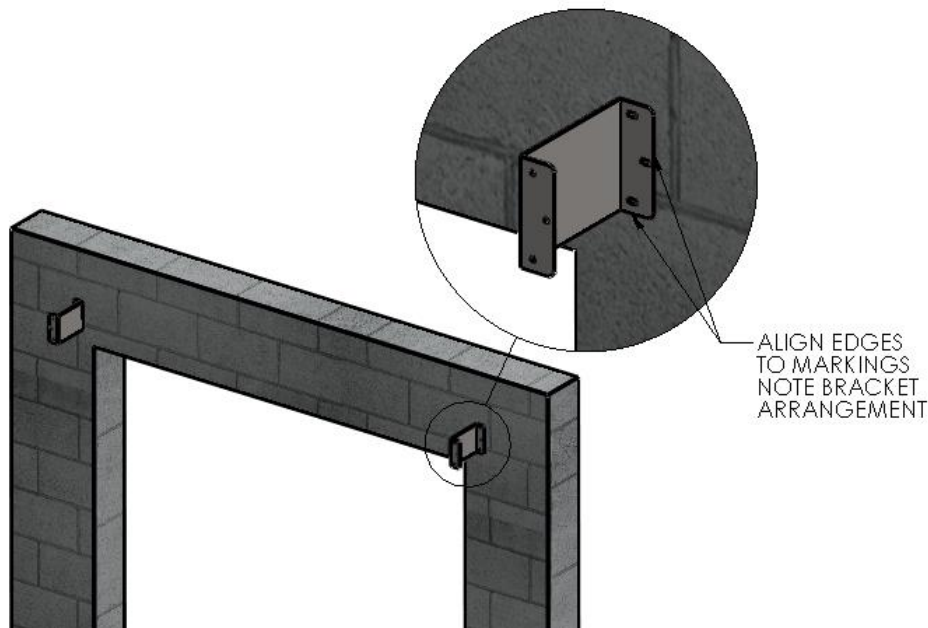

Figure 10 LOCATE/INSTALL HEADER OFFSET MOUNTING BRACKET

RAISE AND ATTACH THE ROLL HEADER ASSEMBLY

1. Using two (2) people, and two ladders at minimum, raise the Roll Header Assembly into place on the offset brackets and secure with three (3) sets of ¼-20 screws and hex nuts per side. Do not fully tighten hardware until the Header Assembly Brackets are aligned with the offset brackets/edges.
(Figure 11 MOUNT HEADER ASSEMBLY TO OFFSET BRACKETS)
2. Once aligned, fully tighten all six sets of hardware. Check the Header Assembly for level, and make any necessary final adjustments.
3. At this point leave the roll assembly tied off and held in place as it comes.

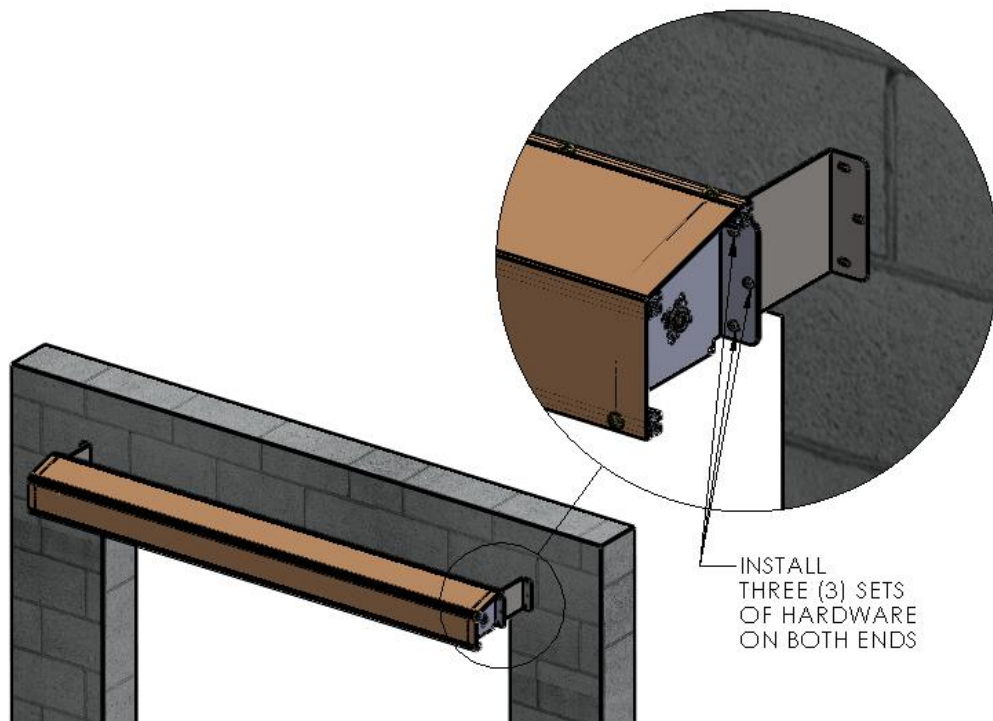

Figure 11 MOUNT HEADER ASSEMBLY TO OFFSET BRACKETS

PREPARE THE VERTICAL TRACK ASSEMBLIES

Note: The Tracks have hardware installed for the Projection Bracket mounting. Also, they are marked for orientation as Left Side, and Right Side.

1. Lay the two Vertical Track Assemblies on your work surface, and un-roll the Side Seal material.
2. Locate the Track Projection Mount Brackets, four (4) per Track, and four the ¼-20 Screws and Flanged Nuts.
3. Remove the Plug from the front of the Track, then push a screw through the hole in the back surface from the inside of the Track.
4. Slip the Projection Bracket with the hole facing the Track, and then thread the nut, onto the screw. The slotted end of the Projection Bracket will fasten to the mounting surface in a later step. These brackets should be mounted so that they are horizontally oriented, i.e. so that they are parallel to the floor (NOT vertically oriented /up and down). (Figure 12 TRACK PROJECTION BRACKET ARRANGEMENT)
5. Fully tighten the hardware for these brackets once they are aligned with the Track edges. Re-install the Plug Caps into the hardware access holes on the front side of these Tracks.

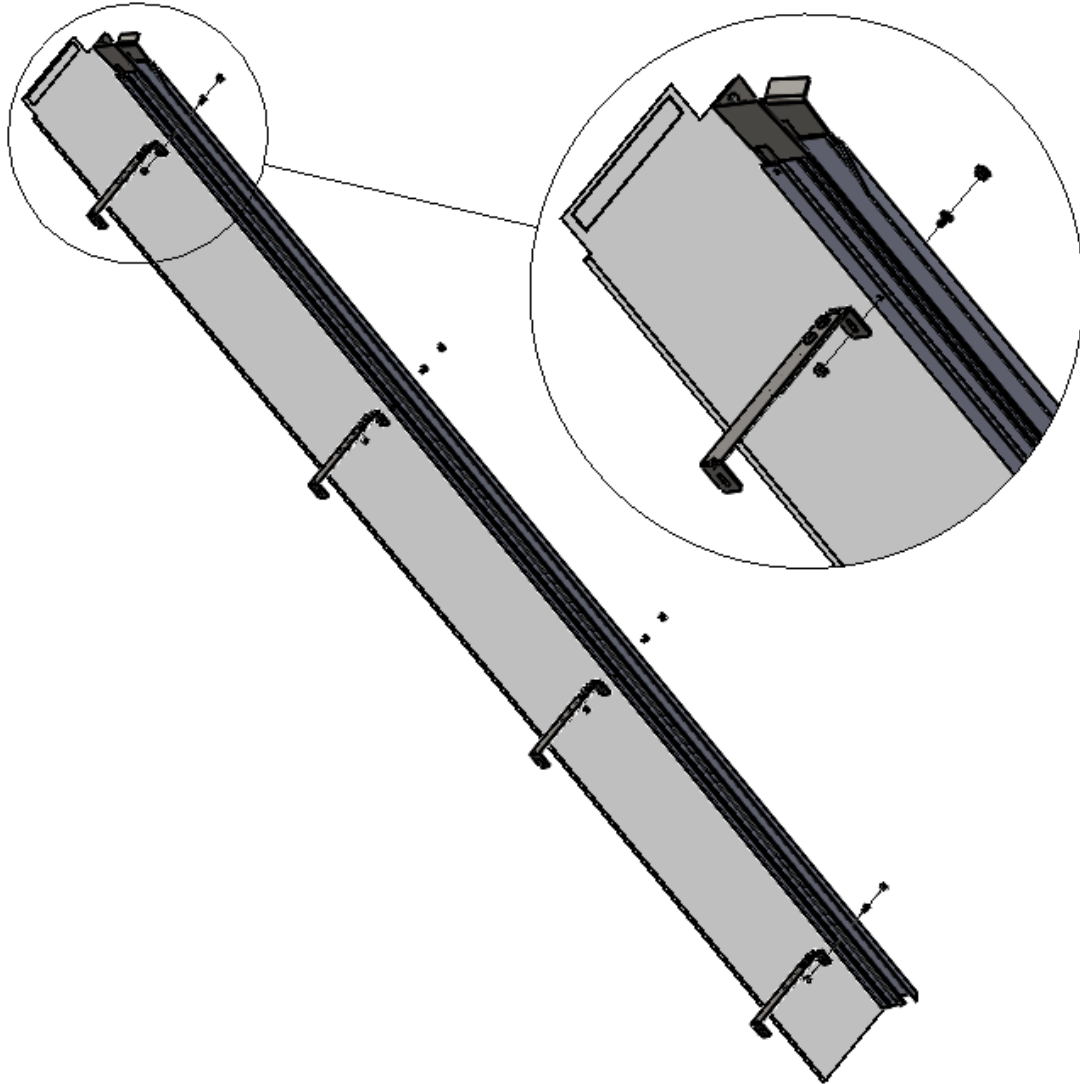

Figure 12 TRACK PROJECTION BRACKET ARRANGEMENT

MOUNT THE VERTICAL TRACKS

1. Starting with either left or right side, loosely “hang” the track assembly by its Track Mounting Hardware. Setup and generally align the track under its respective Roll Assembly Mount Bracket. (Figure 13 TRACK MOUNTING HARDWARE (Figure 13 TRACK MOUNTING HARDWARE)
2. Now align the square hole in the metal Transition Bracket of the Track Assembly with the square bolt hole in the lower mounting tab on the Header bracket above.

Note that the Transition Bracket of the Track Assembly should be inside of the Header bracket tab. Insert the carriage bolt from the inside of the transition and the washer and hex nut on the outside of the assembly, as shown. Just snug this hardware for now. (Figure 14 MOUNT TRACK TO HEADER (Figure 14 MOUNT TRACK TO HEADER)

3. With the track “hanging” in this position, plumb the track to make sure it is vertically aligned, and that its standoff brackets are touching the wall/mount surface. Usually with two people (one holding the track assembly in place), use a marker to trace the oval shaped mount holes on the wall to mark their pilot hole locations.
4. Move the track assembly off to the side and predrill its mounting holes. Move it back into place and secure it to the wall with appropriate hardware. Be sure to plumb each track and check vertical alignment before fully tightening hardware. The Track to Header Hardware will be removed and replaced in the next step, so snug them for now.

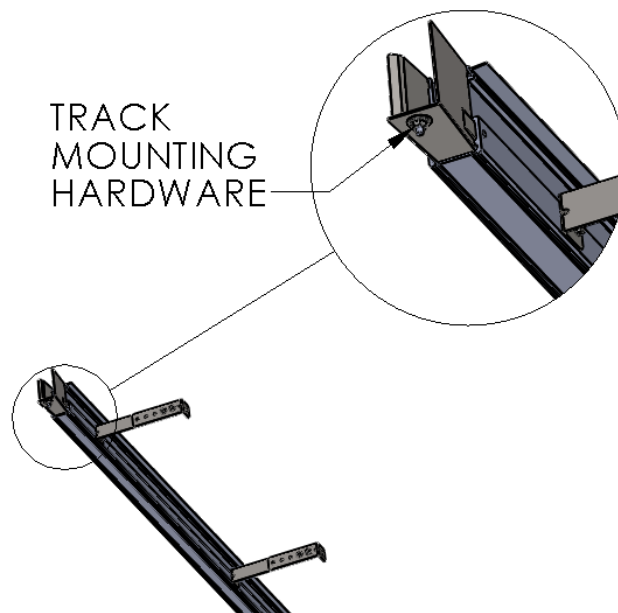

Figure 13 TRACK MOUNTING HARDWARE

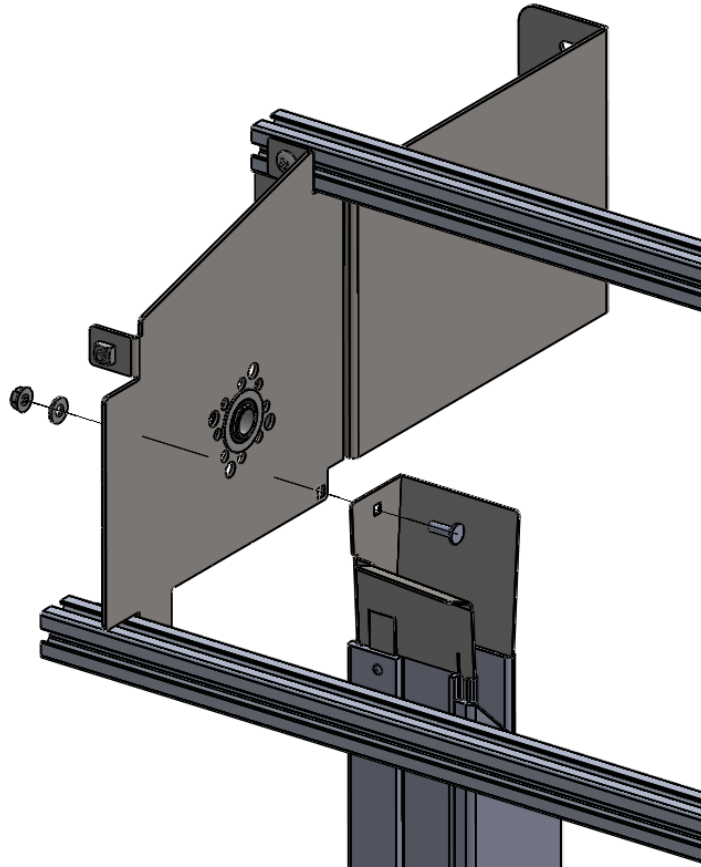

Figure 14 MOUNT TRACK TO HEADER

MOUNT THE SIDE SEAL

1. Remove the nut and washer from the Track Transition Bracket, and re-install them over the Side Seal grommet. Secure the top edge of the Side Seal to the Header Projection Brackets via the hook-and-loop strips provided in the hardware bag.
(Figure 15 SECURE SIDE SEAL)
2. Fold the Side Seal Material to flatten it against the wall, and secure it through the material into the wall with appropriate screws. (Figure 15 SECURE SIDE SEAL)

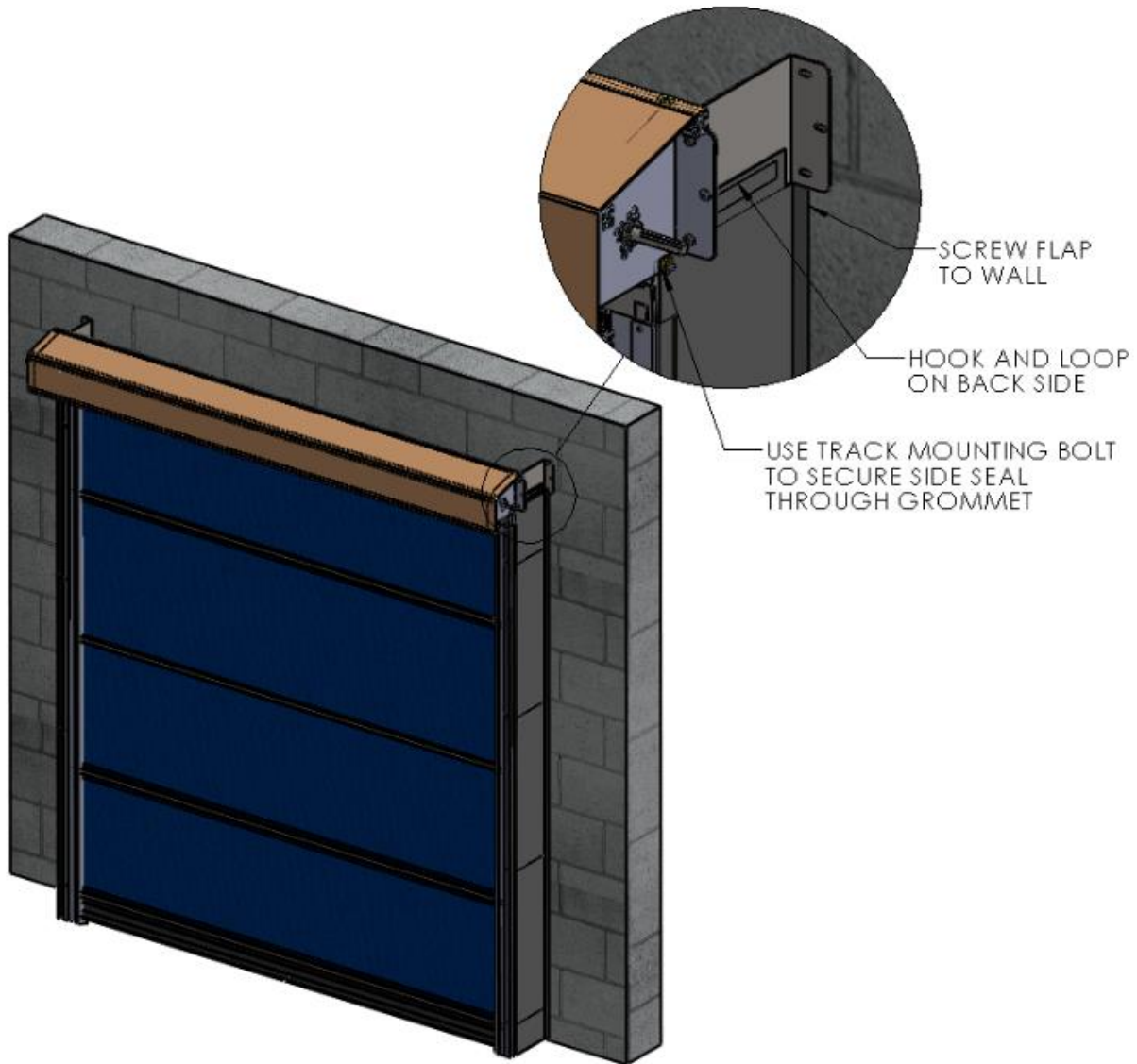
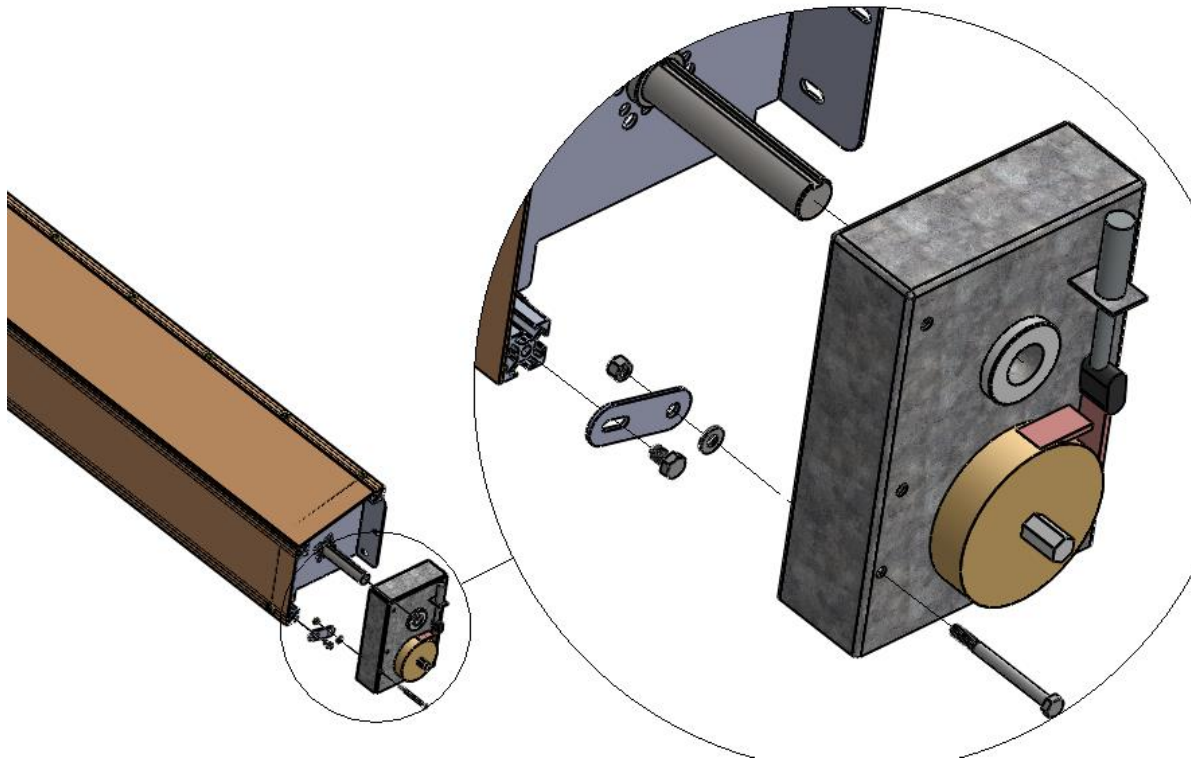

Figure 15 SECURE SIDE SEAL

CHECK ALL MOUNTINGS AND INSTALL OPERATOR

1. With everything mounted, take a moment to check all of your hardware, and all of the components for horizontal and vertical alignments.
2. Insert the provided 1/4" Sq. Key stock into the Chain Hoist Key Way, and slip the Chain Hoist Operator onto the 1" Dia. Drive Shaft.

3. Insert the 3" long Hex Bolt through the width of the Chain Hoist Operator, through the washer and flat Bracket, and secure with the Nylon Hex Nut.
4. Secure the Hex Bolt through the flat Bracket, and into the end of the Aluminum Extrusion.
5. Release the ties on the roll assembly.



WARNING

ALL INSTALLATION INSTRUCTIONS MUST BE FOLLOWED, AND CRITICAL ALIGNMENT REQUIREMENTS MUST BE MET.

- ENSURE THAT THE ROLL HEADER ASSEMBLY IS LEVEL, AND THAT THE TRACKS AND BRACKETS ARE ALL PLUMB, AND SQUARE-

OTHERWISE, THE PERFORMANCE AND CONSISTENT OPERATION OF YOUR DOOR WILL BE COMPROMISED.

LIMITED WARRANTY

G1 Bug Screen/Vinyl Doors



Goff's Enterprises, Inc. warrants all G1 bug screen/vinyl doors from failure in normal use due to defects in material or workmanship for a period of **TWO years** from date of purchase with warranty related labor for the first year as approved by Goff's Technical Support Team.

Goff's Enterprises, Inc. may elect to repair or replace defective or damaged goods.

Technical Support Team: 262-746-3374