



READ THIS MANUAL CAREFULLY. OBSERVE WARNINGS AND PRACTICE CAUTION WHEN INSTALLING, OPERATING, OR MAINTAINING YOUR GOFF'S PRODUCT.

MAINTAINED TOGGLE SWITCH

ELECTRICAL CONNECTIONS AND MOTOR ADJUSTMENTS

USED WITH 600, 1200 AND 1800 SERIES IN-TUBE MOTORS

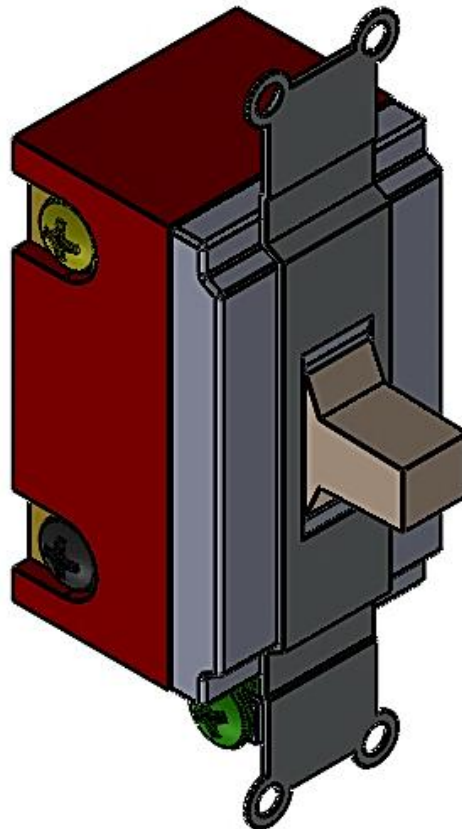

ELECTRICAL CONNECTIONS:

The electrical connections to the in-tube motor should be made in a manner that conforms to all local and national electrical codes. The use of a licensed electrical professional is strongly recommended.

The Roll Tube Motor is controlled by a single “maintained” center-off toggle switch. **Only one** switch can be used per motor and wiring multiple switches in parallel or series will **NOT** allow for proper operation of the motor.

ONE MOTOR / SINGLE POLE SWITCH

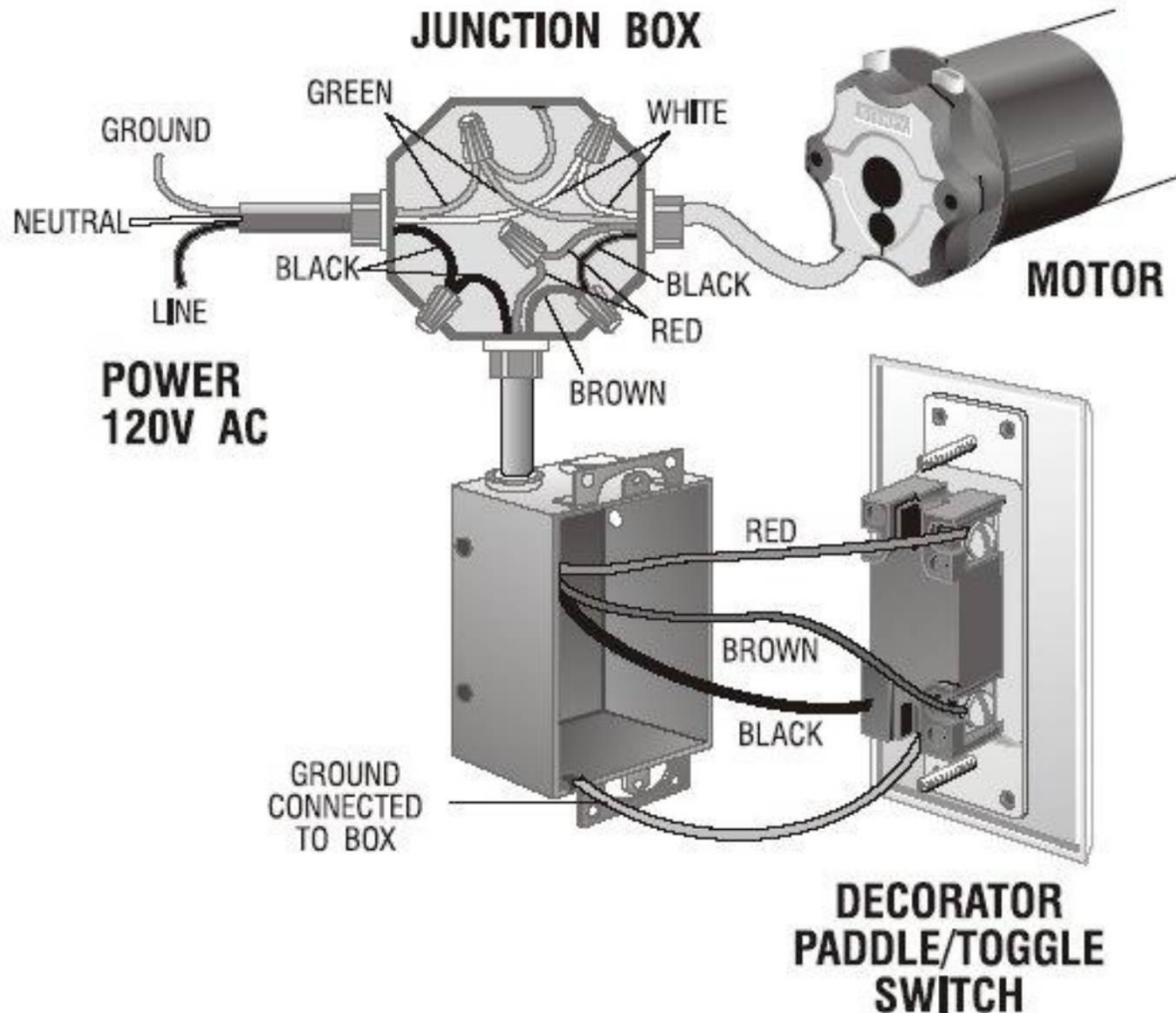

Figure 1: Toggle Switch Wiring for In-Tube Motor

MOTOR AND LINE-IN WIRING:

- *See Figure 1 for appropriate AC Power wiring for your motor*
- **NOTE:** Your switch may not exactly represent the unit depicted in the above diagram. If not, connect the BLACK (AC Power HOT) to the BLACK screw on the switch. Connect the BLACK (Motor Direction #1) to one of the brass-tone screws, and connect the RED (Motor Direction #2) to the remaining brass-tone screw.

- Using a chassis ground in the switch's housing, connect it to the GREEN screw on the switch.
- NOTE: The GREEN Motor wire and the GREEN ground from your line-in terminate at the chassis of a junction box (See Figure 1).
- The WHITE Motor wire and the WHITE Neutral Line-In wire tie together in a wire nut.

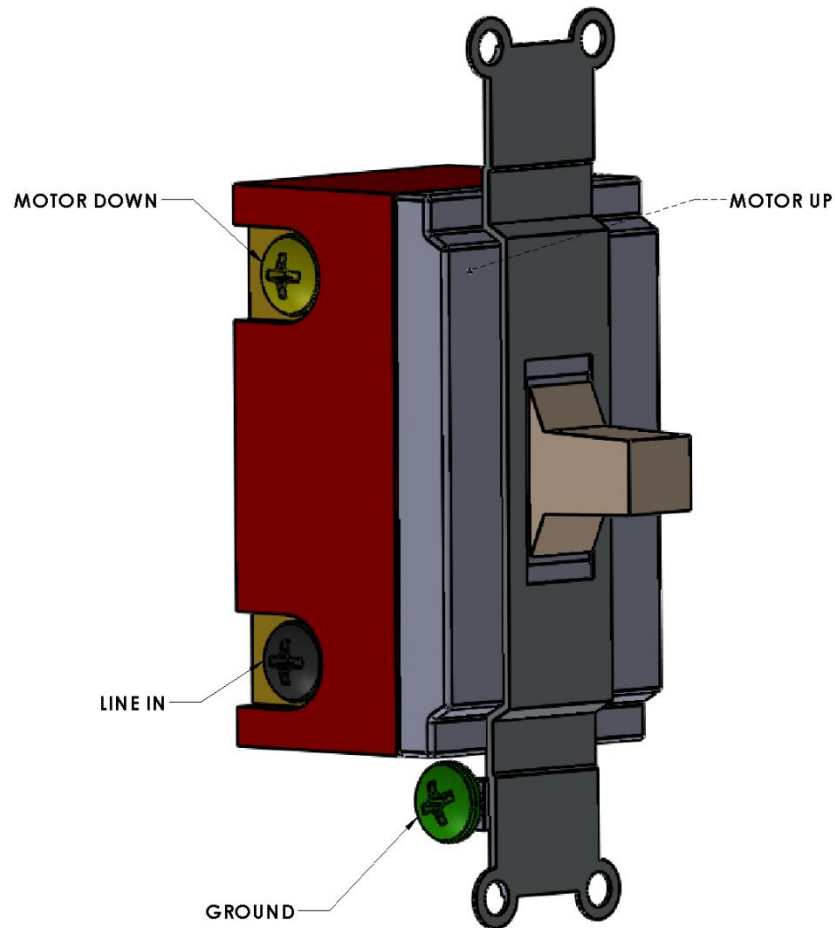

Figure 2: Toggle Switch Terminal Locations

After the power wiring has been installed (and power has been enabled to the unit) it will be necessary to check/modify the direction of motor rotation. Care should be exercised during these operations to avoid damage to the assembly and ensure a long service life of the unit.

- To reverse the direction of operation, swap the red and black motor wires on the toggle switch

SETTING THE LIMITS:

- Observe which type of limit adjustment mechanisms you have:
 1. 600 Series Doors have button limits
 - Top Button = Close Limit
 - Bottom Button = Open Limit

 - Buttons 'IN' = Limit Disengaged (no limit)
 - Button 'OUT' = Limit Enabled (limit on)
 2. 1200/1800 Series Doors have dial limits
 - Top Dial = Close Limit
 - Bottom Dial = Open Limit

 - Clockwise Turn = Adding Door Travel
 - Counter-Clockwise Turn = Removing Door Travel

For 600 Series Doors:

- Always, **FIRST JOG THE DOOR DOWN** toward the closed position. Observe where the lower limit stops the door and adjust accordingly by depressing the upper button at the end of the motor. (See Figure 4 on page 5) Run the door partially upward, stop, and then close again a few times up and down to make finer adjustments for the closed position as desired.
- Now open the door and note the upper stop point. Adjust in the same way using the lower button at the end of the motor. (See Figure 4 on page 5) Repeat a few times until the desired upper stop position is finally achieved.

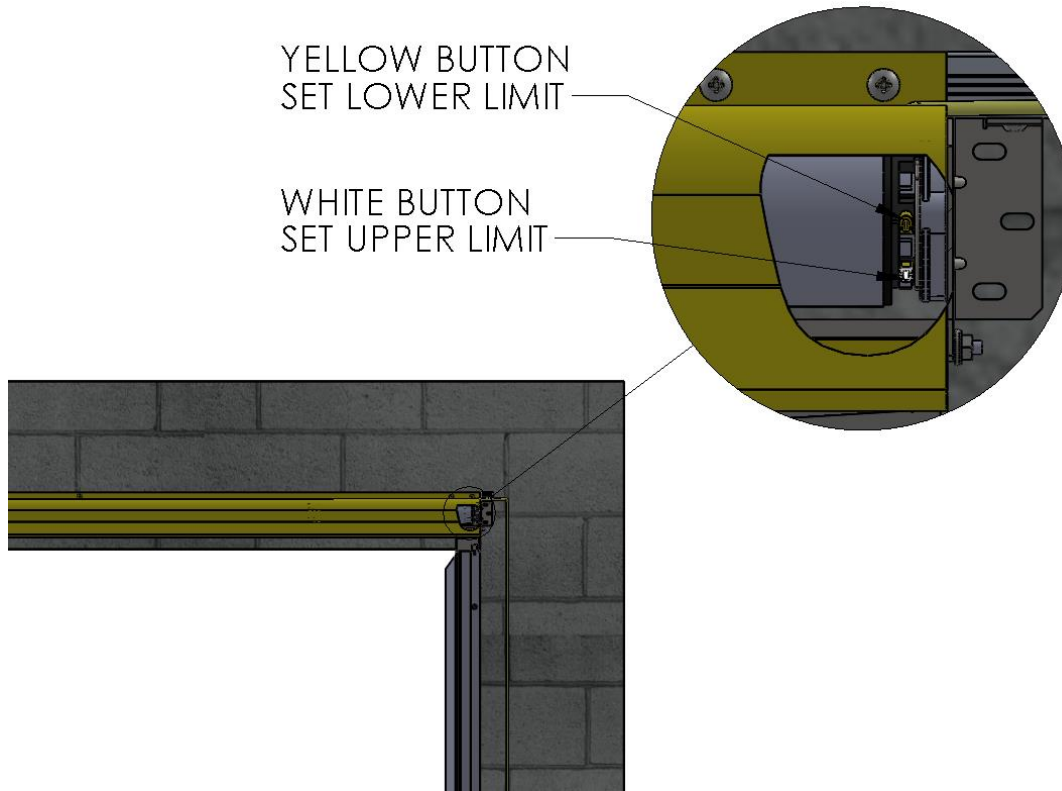

Figure 4: 600 SERIES DOOR RAISE/LOWER DOOR ADJUSTMENT

For 1200/1800 Series Doors:

- Always JOG THE DOOR DOWN FIRST, toward the closed position. Stop the door about 1 to 2 feet above the desired closed position. Now, turn the top dial on the end of the motor counter-clockwise (ccw) to remove travel from the close limit. Keep turning ccw until you feel or hear a slight bump/click in the dial as you turn. Once you reach this point, whether your door stopped on its own, or you stopped it yourself and removed travel manually from the dial, we are ready to set the limit at our desired closed position.
- Now flip the toggle switch down and leave it there. The door SHOULD NOT MOVE. If it does, stop it, and add more ccw turns to the top dial. Once there is no movement, flip the toggle switch down, and leave it there, while adding clockwise turns to the top dial. As you turn the dial clockwise, the door will inch itself down. Continue to add clockwise turns to the top dial until the door inches itself into your desired closed position.

- To set the Open limit, jog the door up and stop it 1-2 feet shy of the desired open position. Adjust this limit in the same fashion as you did the close limit, using the lower dial on the motor

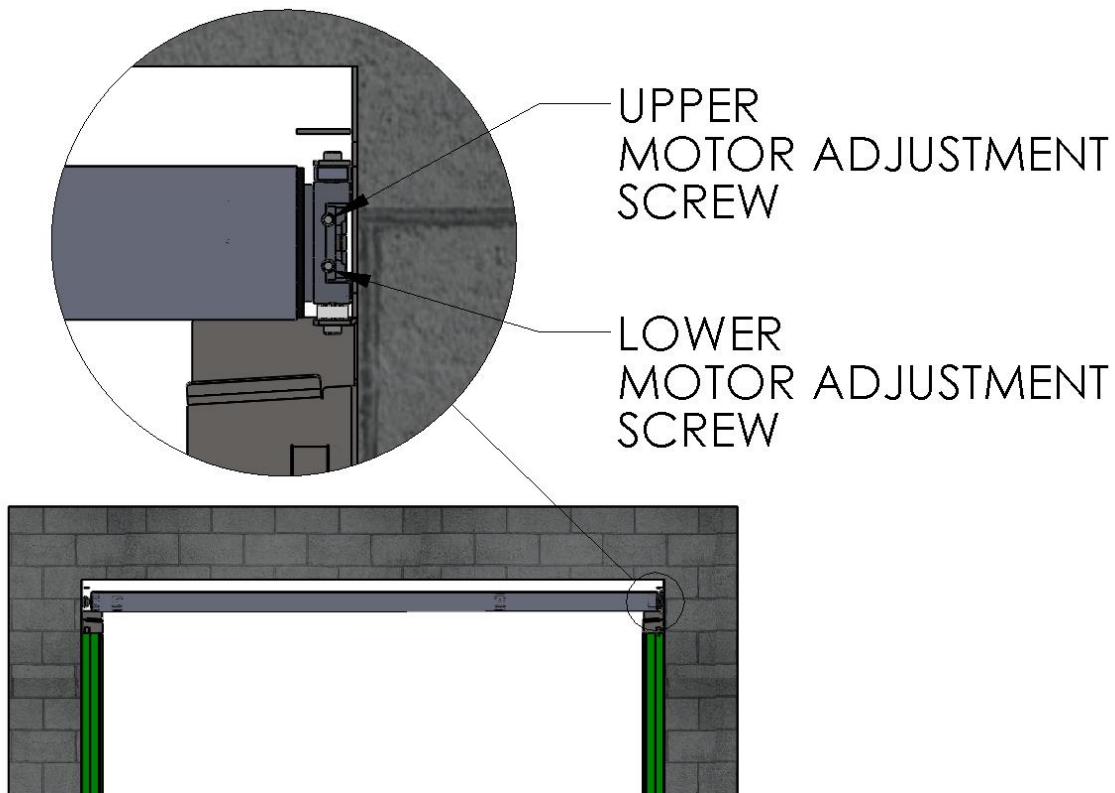

Figure 5: 1200/1800 SERIES DOOR RAISE/LOWER DOOR ADJUSTMENT

TROUBLESHOOTING:

- Door moving in the wrong direction
 1. Reverse the RED and BLACK Motor wires connected to the brass-tone screws on the toggle switch.
- Door stuck in open position
 1. Add travel to the lower limit (See 'SETTING THE LIMITS").
 2. If 600 Series door(s), make sure limit button is pressed/depressed completely when adjusting.
- Door stuck in closed position
 1. Add travel to the upper limit (See 'SETTING THE LIMITS").
 2. If 600 Series door(s), make sure limit button is pressed/depressed completely when adjusting.

Goff's Enterprises ALWAYS recommends having a qualified Electrician mount the Switch Control Box, route, and connect all wiring before applying power to the Door Assembly. Goff's is not responsible for issues that are a result of poor and/or improper installation or electrical work.

WARNING

ALL INSTALLATION INSTRUCTIONS MUST BE FOLLOWED, AND REQUIREMENTS MET. FAILURE TO DO SO WILL ALTER THE PERFORMANCE AND/OR CONSISTENCY OF YOUR DOOR'S OPERATION.