

G2 5400 SERIES – FLUSH MOUNTED COMMERCIAL VINYL DOOR INSTALLATION INSTRUCTIONS

READ THIS MANUAL CAREFULLY. OBSERVE WARNINGS AND PRACTICE CAUTION WHEN INSTALLING, OPERATING, OR MAINTAINING YOUR GOFF'S DOOR ASSEMBLY.

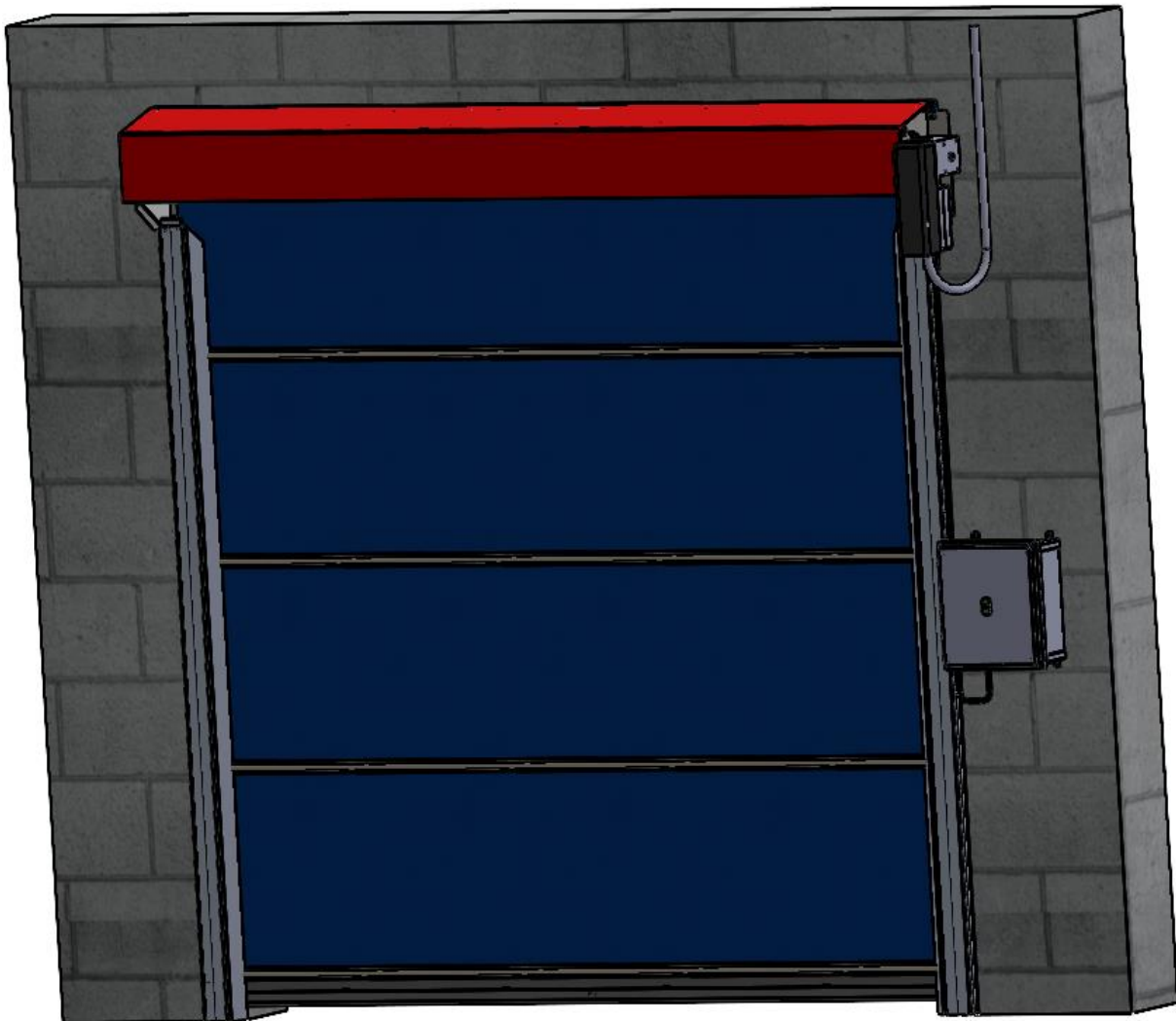

PREPARE MOUNTING SURFACE

1. Measure the width the existing opening, or frame, near the top of the opening. Divide that overall width measurement in half to find and clearly mark the center at the top of the door frame or its header. (Figure 1 MEASURE/MARK OPENING)
2. Place the G2 Door Roll Header Assembly across a safe and level work surface, then rotate the roll assembly frame so that the Header Bracket mount flanges are facing upward. (Figure 2 MEASURE DOOR WIDTH).
3. Measure the entire width of the Roll Header Assembly from the outermost edge of one Header Bracket mounting flange to the outermost edge of the opposite side. (Figure 2 MEASURE DOOR WIDTH)
4. Divide that number by 2 and measure to each side of the center mark from step 1. Mark a vertical line above the opening at these locations. This is where the outermost edges of the Header Bracket mount flanges will be. (Figure 3 MARK DOOR WIDTH ON WALL)
5. Set one of the Vertical Track Assemblies on your work surface and measure its overall length. Do not include the Transition piece in your measurement. Add $\frac{1}{4}$ " to this number and take note. This is the height dimension needed to mark the location of the Header Bracket's bottom edge. With that number, mark a horizontal line on each side of the opening that intersects the previously drawn vertical line.
(Figure 4 MEASURE TRACK HEIGHT) (Figure 5 MARK TRACK HEIGHT)
6. Using two (2) people, and two ladders at minimum, raise the Roll Header Assembly to fit between, and above, your markings on the wall. Trace the insides of the Header Bracket's three (3) mounting slots onto the wall surface (a Sharpe permanent marker works great for this). Be sure that the Mounting Bracket's bottom edge is on the height line, and that the outer edge is on your vertical/width line.
7. Pre-drill pilot holes for the mounting hardware at the centers of the traced locations. Using adequate mounting screws or bolts (depending on your building/surface material) attach the Roll Header Bracket to each side of the opening.

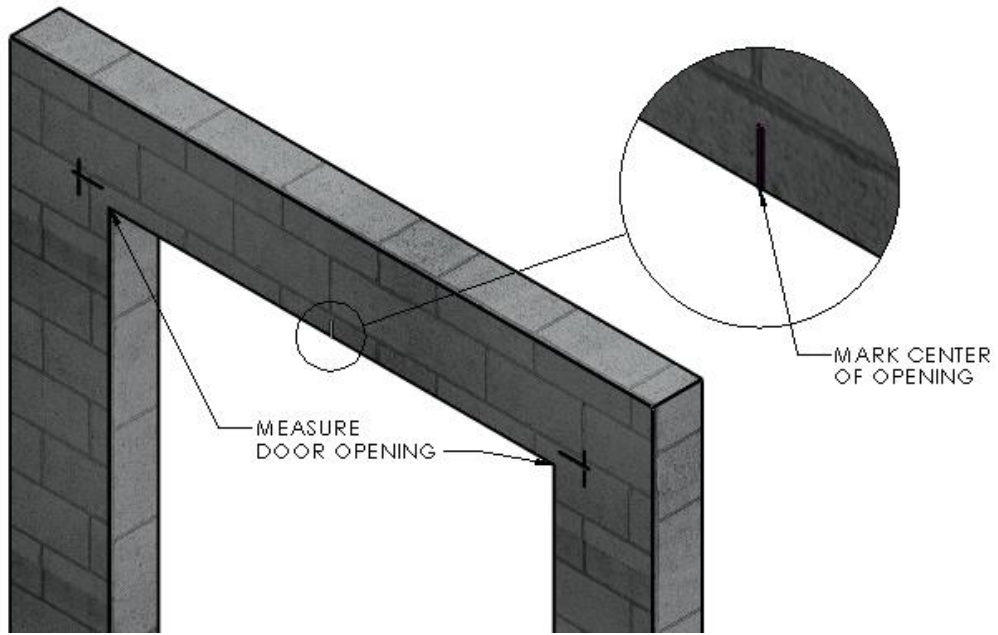

Figure 1 MEASURE/MARK OPENING

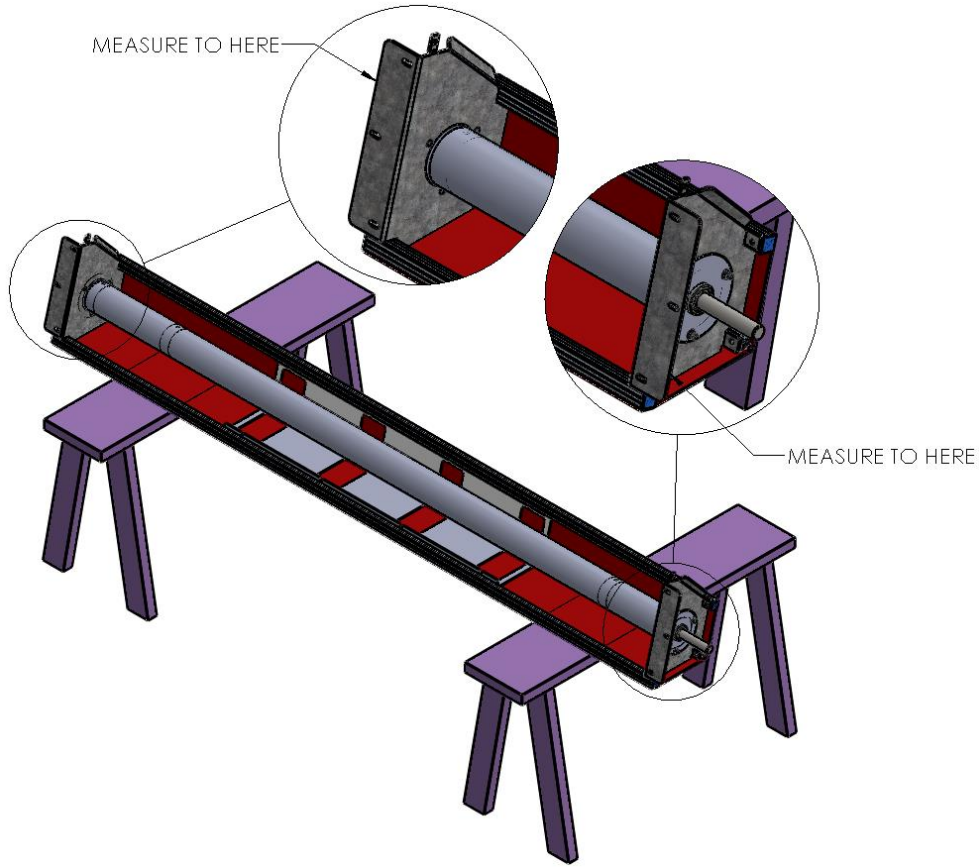

Figure 2 MEASURE DOOR WIDTH

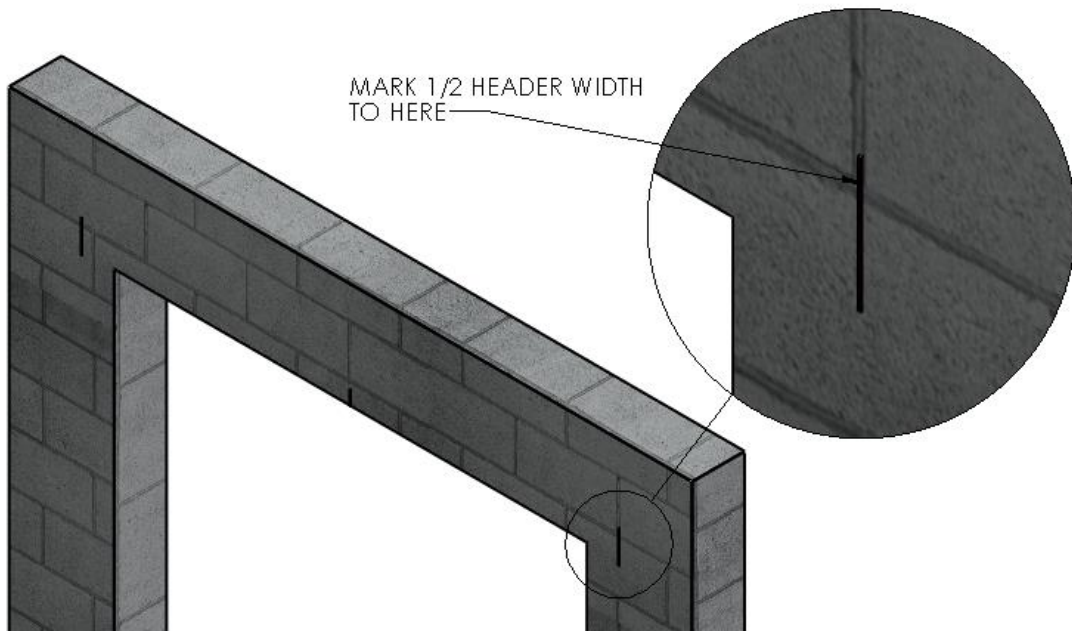

Figure 3 MARK DOOR WIDTH ON WALL

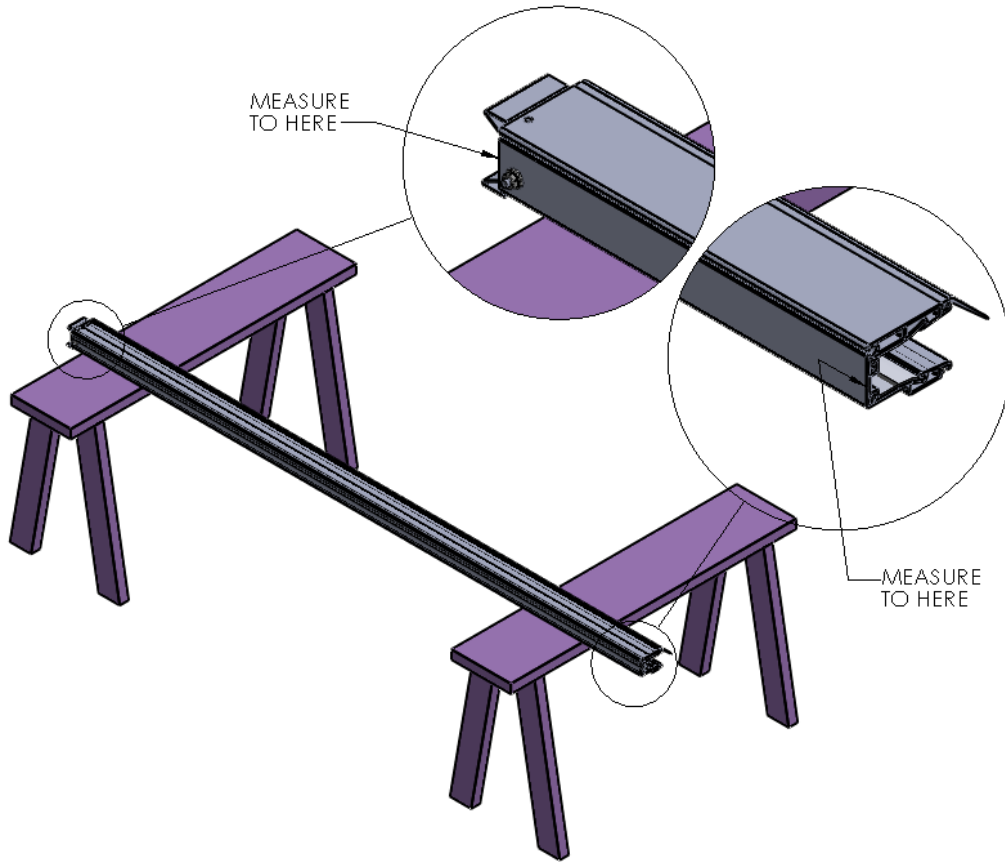

Figure 4 MEASURE TRACK HEIGHT

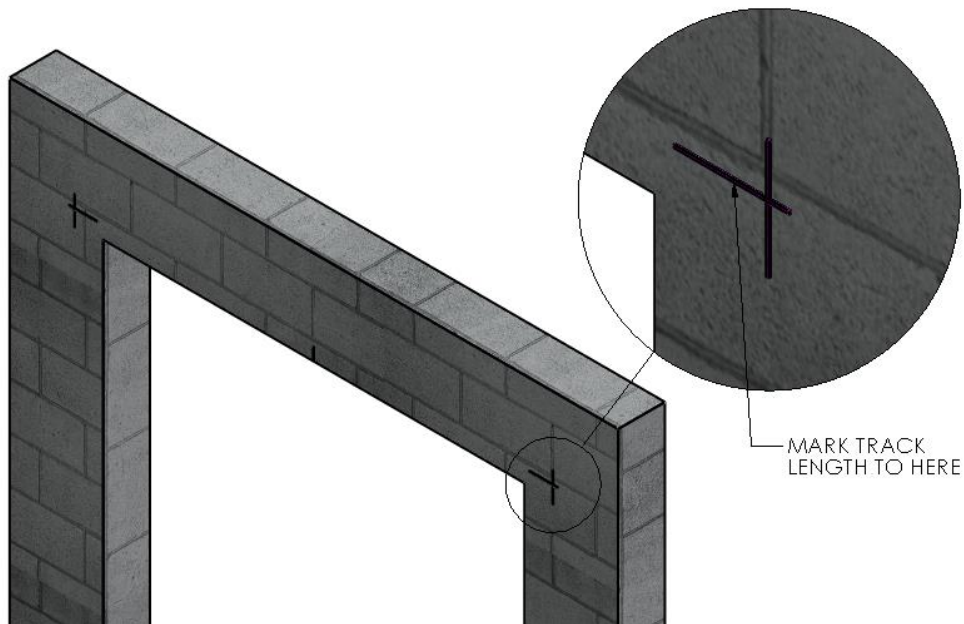

Figure 5 MARK TRACK HEIGHT

RAISE AND ATTACH THE ROLL HEADER ASSEMBLY

8. Using two (2) people, and two ladders at minimum, raise the Roll Header Assembly into place on the wall, and loosely secure with three (3) sets of mounting hardware per side using screws or bolts that are adequate to your building/surface material. (Figure 6 MOUNT HEADER ASSEMBLY TO WALL)
9. Check the Header Assembly for level, and fully tighten all six sets of hardware.
10. At this point leave the roll assembly tied off and held in place as it comes.

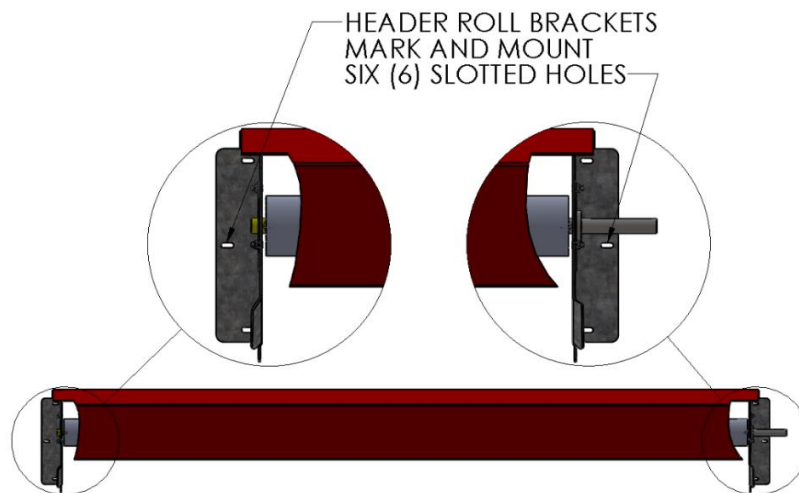

Figure 6 MOUNT HEADER ASSEMBLY TO WALL

PREPARE THE VERTICAL TRACKS

1. Attach a Track Mounting Bracket to the Track in the hole located at the bottom (Figure 7 TRACK MOUNTING BRACKET)

Note: For extreme cases, such as “High Wind Loads”, an additional Track Mounting Bracket (supplied) will be necessary.

2. Mark and Drill the Track (.28-.31 dia) at 1.44” in from the front edge (i.e. centered in the groove), at about mid-height of the Track. (Figure 7 TRACK MOUNTING BRACKET)

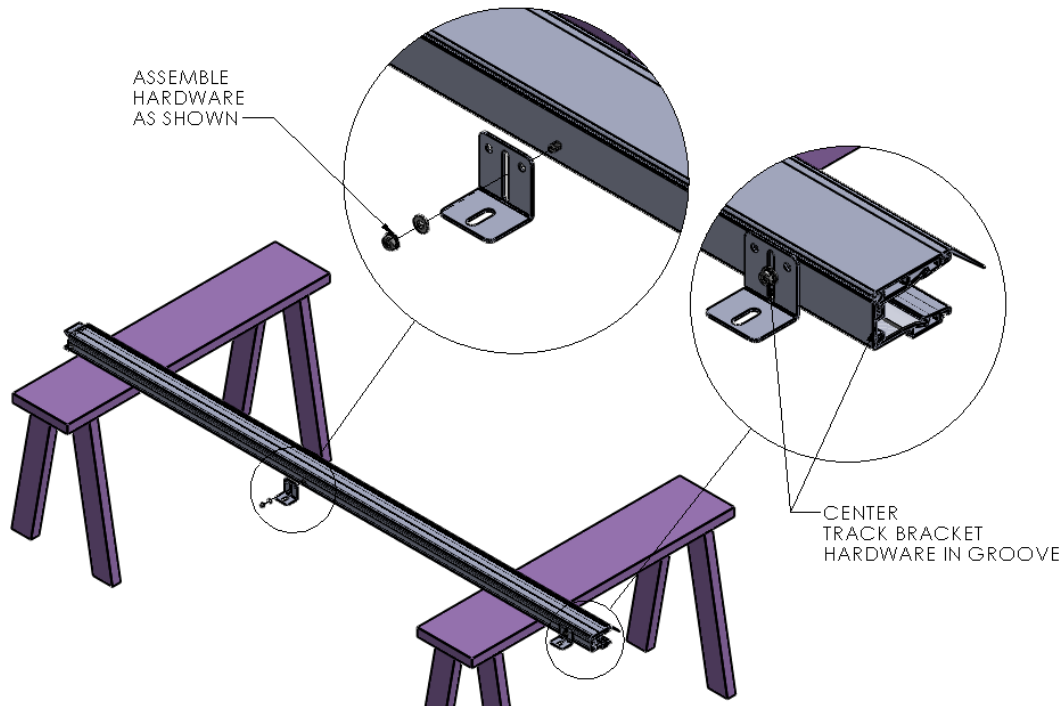

Figure 7 TRACK MOUNTING BRACKET

MOUNT THE VERTICAL TRACKS

1. Starting with either the left or right side, loosely “hang” the Track Assembly from the Header Assembly Mounting Bracket with the Track Mounting Hardware. Note that the Track assembly mounts to the outside of the tab of the Header Assembly Mounting Bracket. It is important to insert the carriage bolt from the inside, and the washer and hex nut on the outside of the assembly as shown. (Figure 8 MOUNT TRACK TO HEADER)

2. With the Track Assembly “hanging” in this position, plumb the Track Assembly to make sure it is vertical. Trace the slot in the bottom Track Mounting Bracket onto the wall. (Figure 9 TRACK INSTALLATION)

3. Move the Track Assembly off to the side and predrill its mounting holes. Move the Track back into place and secure it to the Header Bracket and then to the wall with appropriate hardware. Before fully tightening hardware, be sure each track is plumb/vertical.

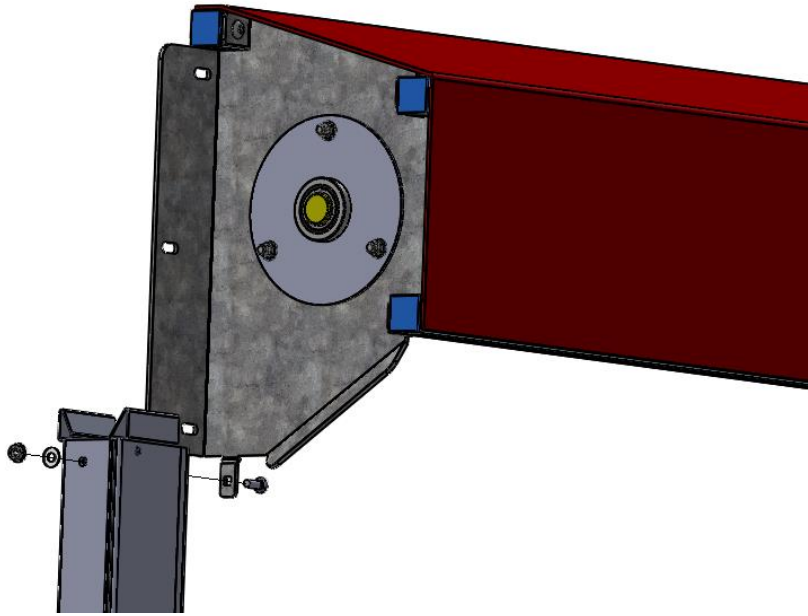

Figure 8 MOUNT TRACK TO HEADER

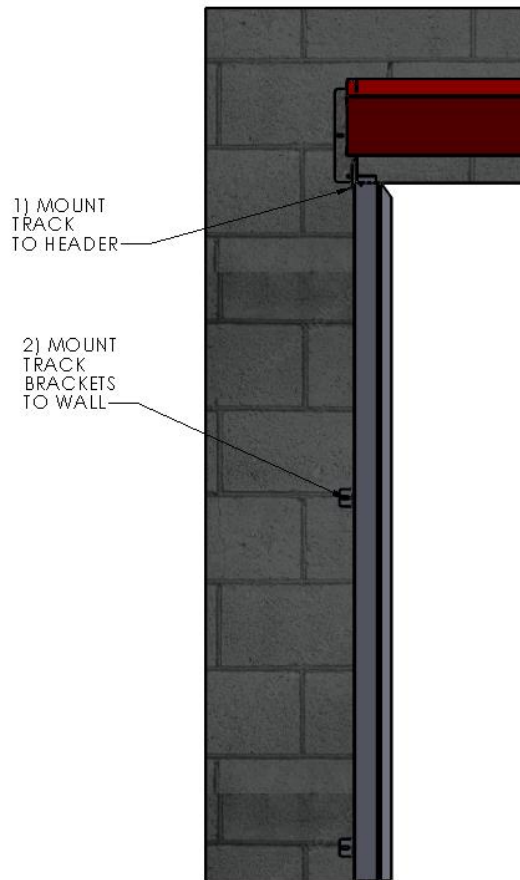

Figure 9 TRACK INSTALLATION

OPERATOR INSTALLATION

1. Mount the Anti-Torque Bracket to the Operator with two (2) Metric screws (supplied). (Figure 10 MOUNT ANTI-TORQUE BRACKET AND OPERATOR)
2. Slide the Operator onto the Drive Shaft
3. Secure the Anti-Torque Bracket to the Header Top Box with the 5/16-18 Hex Bolt (supplied).

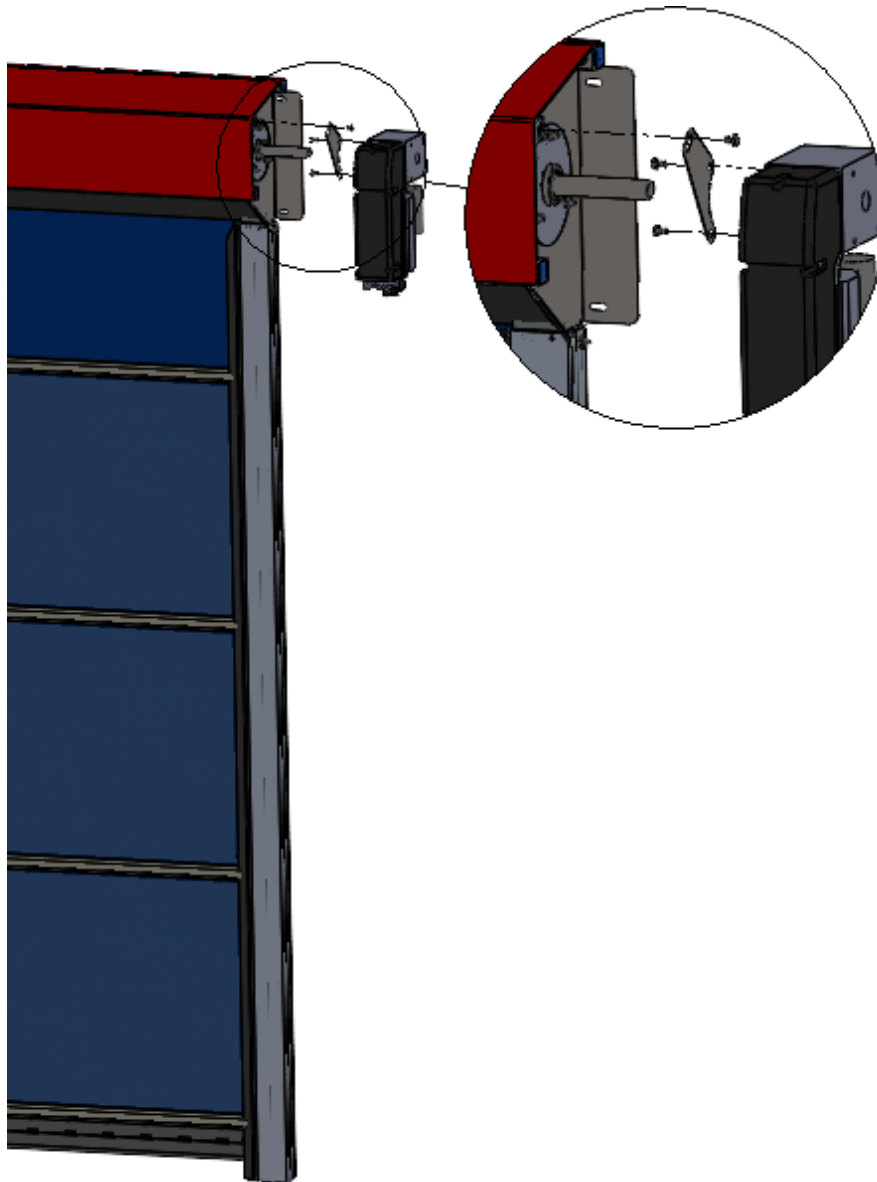

Figure 10 MOUNT ANTI-TORQUE BRACKET AND OPERATOR

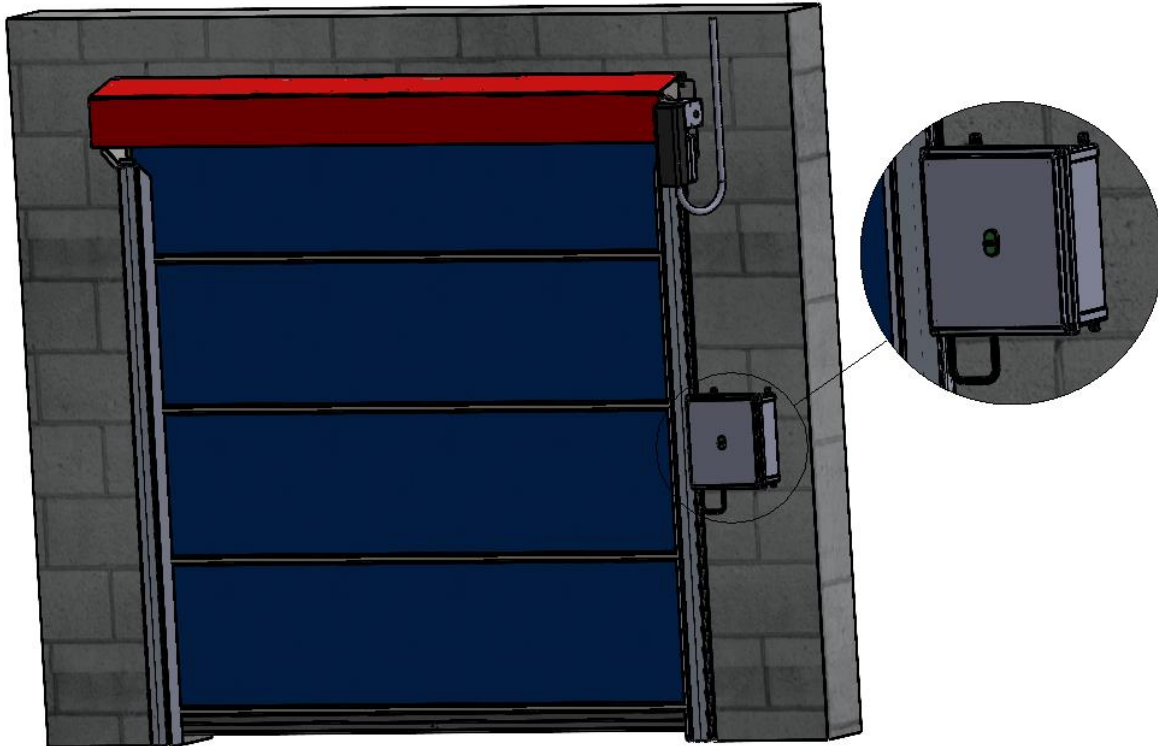

Figure 11 CONTROL BOX LOCATION

CHECK ALL MOUNTINGS AND CONNECT OPERATOR

1. With everything mounted, take a moment to check all of your hardware, and all of the components for horizontal and vertical alignments.
2. Release the ties on the roll assembly.
3. Have a qualified Electrician mount the Switch Control Box, route, and connect all wiring before applying power to the Door Assembly. (Figure 11 CONTROL BOX LOCATION)

NOTE - See supplemental Instruction for:
"Electrical Connections and Motor Adjustments".

WARNING

ALL INSTALLATION INSTRUCTIONS MUST BE FOLLOWED, AND CRITICAL ALIGNMENT REQUIREMENTS MUST BE MET.

- ENSURE THAT THE ROLL HEADER ASSEMBLY IS LEVEL, AND THAT THE TRACKS AND BRACKETS ARE ALL PLUMB, AND SQUARE-

OTHERWISE, THE PERFORMANCE AND CONSISTENT OPERATION OF YOUR DOOR WILL BE COMPROMISED.

LIMITED WARRANTY



G2 Doors

Goff's Enterprises, Inc. warrants all High-Performance Doors from failure in normal use due to defects in material or workmanship for a period of **THREE years** from date of purchase. This warranty includes **all parts and warranty related labor** as approved by Goff's Technical Support Team.

Goff's Enterprises, Inc. may elect to repair or replace defective or damaged goods.

Technical Support Team: 262-746-3374