

G2 1800 SERIES DOOR W/ IN-TUBE MOTOR PROJECTION MOUNTED INSTALLATION INSTRUCTIONS

READ THIS MANUAL CAREFULLY. OBSERVE WARNINGS AND PRACTICE CAUTION WHEN INSTALLING, OPERATING, OR MAINTAINING YOUR GOFF'S DOOR ASSEMBLY.

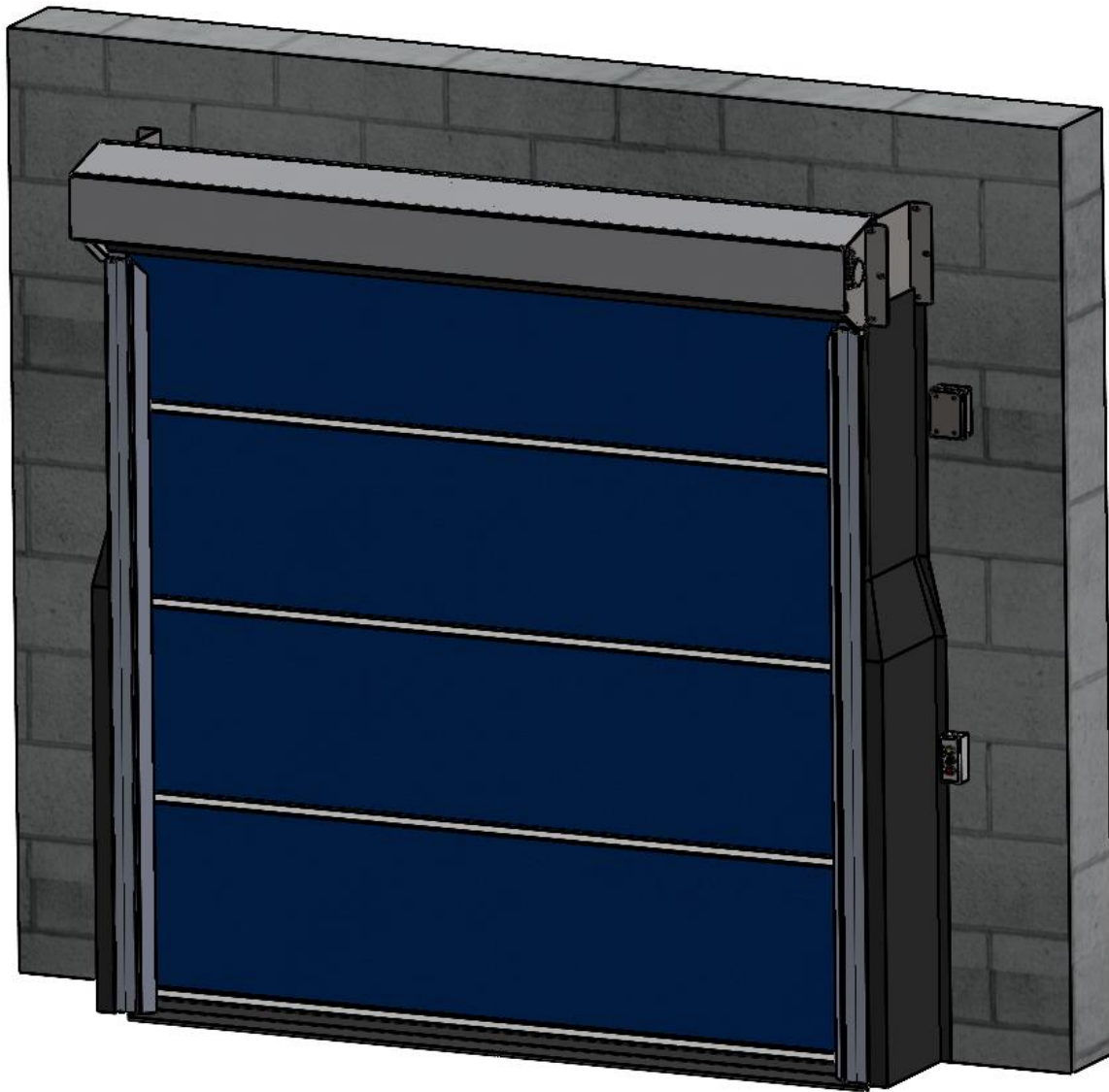

PREPARE MOUNTING SURFACE

1. Measure the width the existing opening, or frame, near the top of the opening. Divide that overall width measurement in half to find and clearly mark the center at the top of the door frame or its header. (Figure 1 MEASURE/MARK OPENING)
2. Place the G2 Door Roll Header Assembly across a safe and level work surface, then rotate the roll assembly frame so that the Header Bracket mount flanges are facing upward. (Figure 2 MEASURE DOOR WIDTH).
3. Measure the entire width of the Roll Header Assembly from the outermost edge of one Header Bracket mounting flange to the outermost edge of the opposite side. (Figure 2 MEASURE DOOR WIDTH)
4. Divide that number by 2 and measure to each side of the center mark from step 1. Mark a vertical line above the opening at these locations. This is where the outermost edges of the Header Bracket mount flanges will be. (Figure 3 MARK DOOR WIDTH ON WALL)
5. Set one of the Vertical Track Assemblies on your work surface and measure its overall length. Do not include the Transition piece in your measurement. Add $\frac{1}{4}$ " to this number and take note. This is the height dimension needed to mark the location of the Header Bracket's bottom edge. With that number, mark a horizontal line on each side of the opening that intersects the previously drawn vertical line. (Figure 4 MEASURE TRACK HEIGHT) (Figure 5 MARK TRACK HEIGHT)

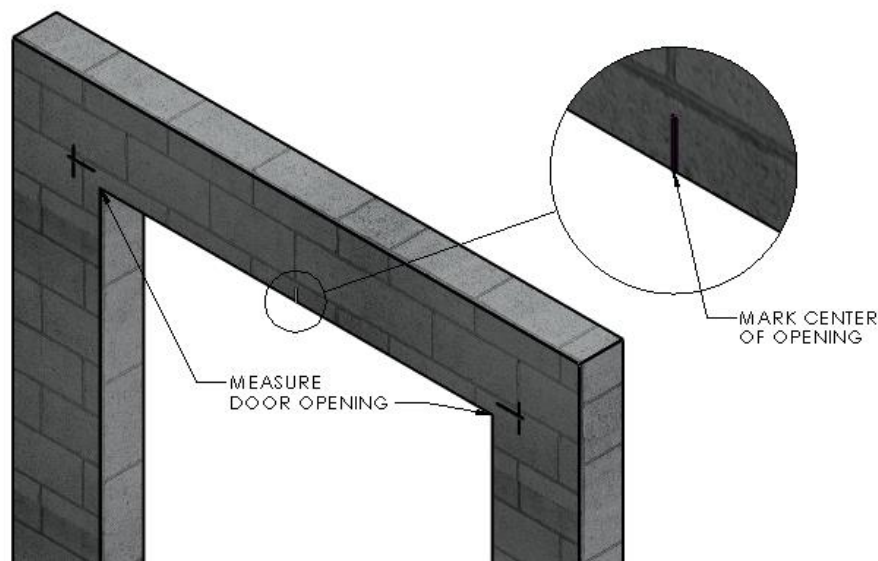

Figure 1 MEASURE/MARK OPENING

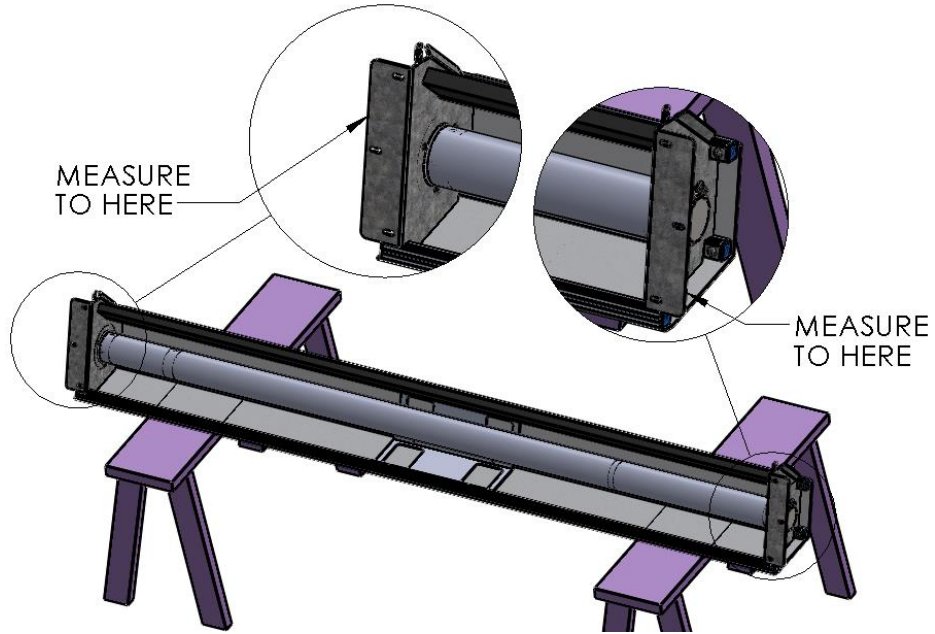

Figure 2 MEASURE DOOR WIDTH

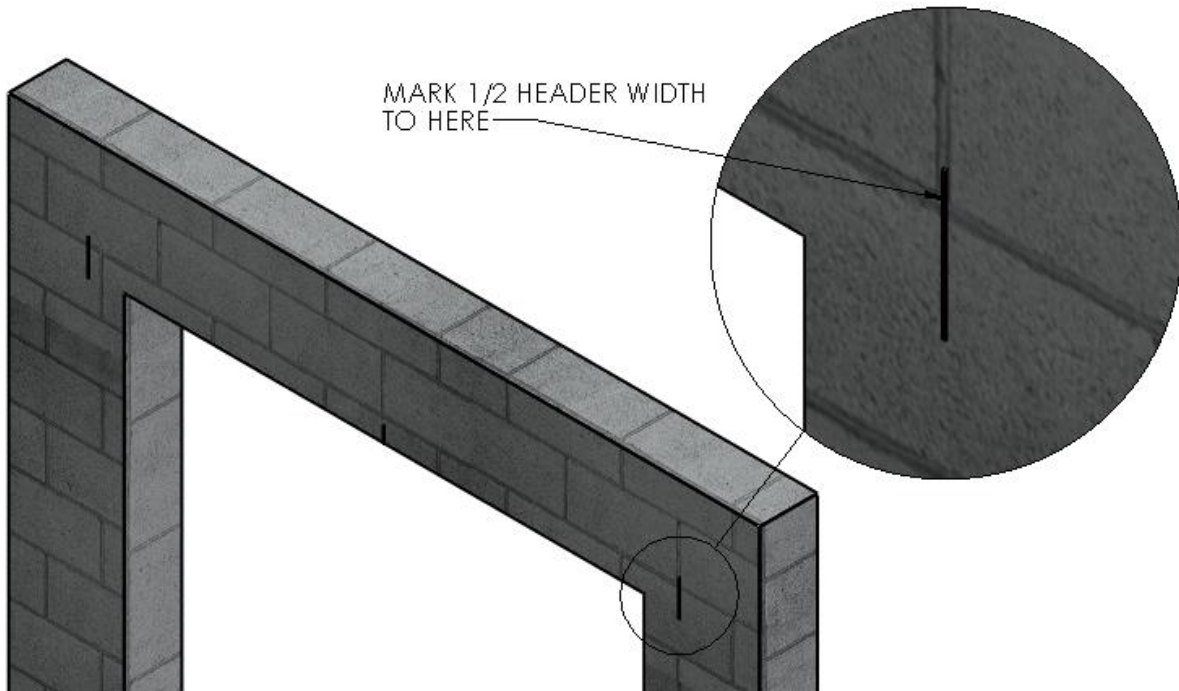

Figure 3 MARK DOOR WIDTH ON WALL

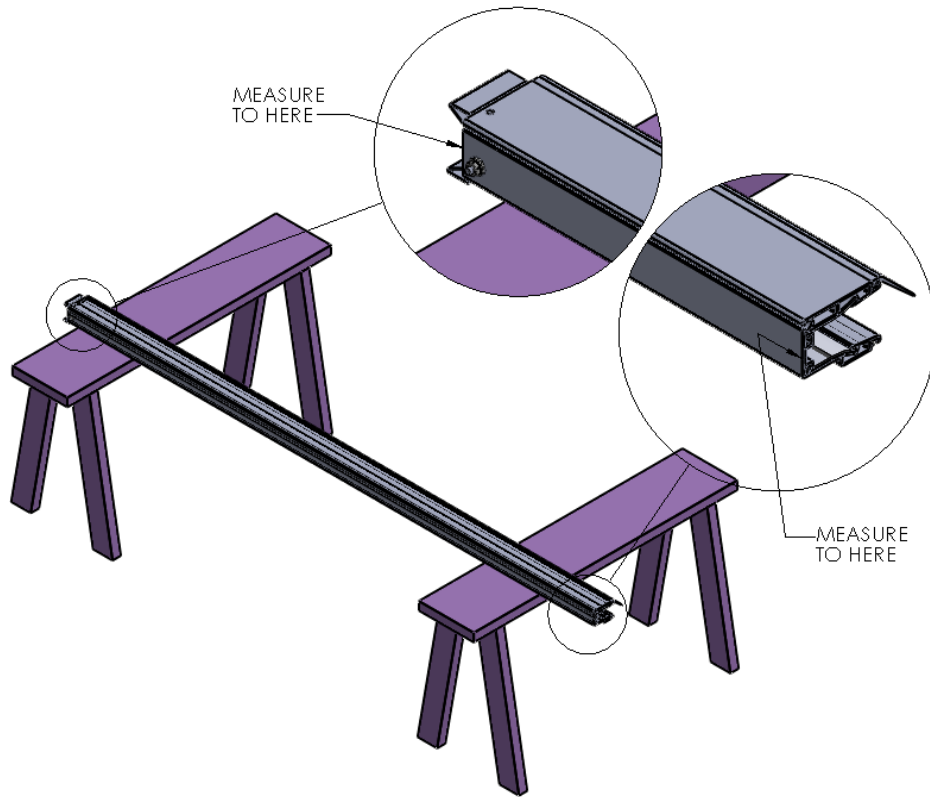

Figure 4 MEASURE TRACK HEIGHT

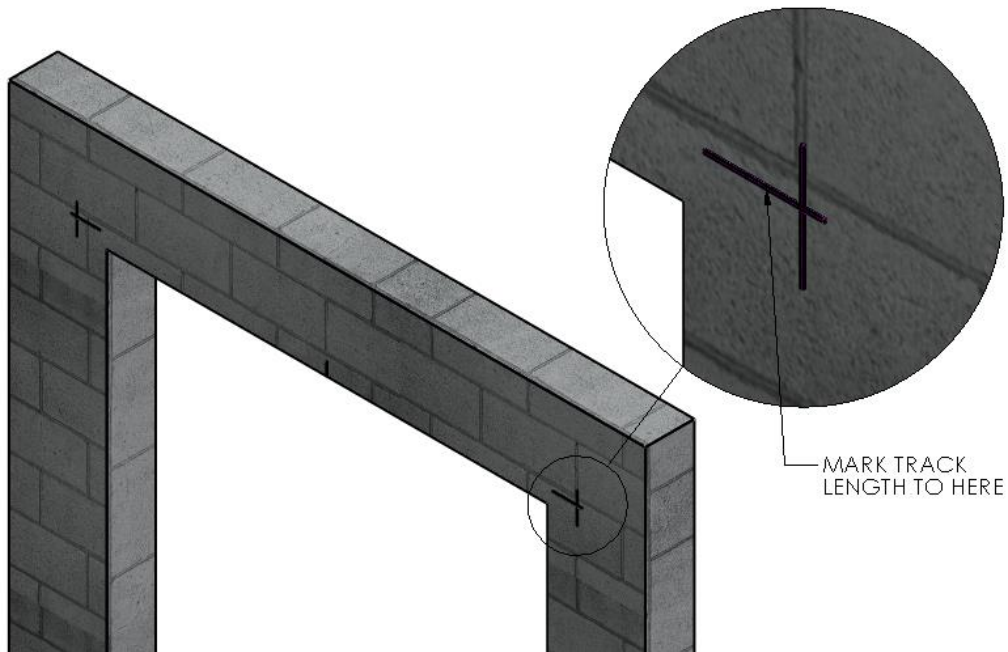

Figure 5 MARK TRACK HEIGHT

G2 SERIES DOORS – PROJECTION MOUNTING INSTALLATION INSTRUCTIONS

READ THIS MANUAL CAREFULLY. OBSERVE WARNINGS AND PRACTICE CAUTION WHEN INSTALLING, OPERATING, OR MAINTAINING YOUR GOFF'S DOOR ASSEMBLY.

PREPARE PROJECTION BRACKETS

1. Find the package of Header Projection Mount Brackets, and a bag with screws, nuts and Velcro strips. (Figure 6 HEADER PROJECTION BRACKET PACKAGE)
2. Find and assemble the Track Projection Brackets as shown (Figure 7 TRACK PROJECTION BRACKET COMPONENTS AND ARRANGEMENT)

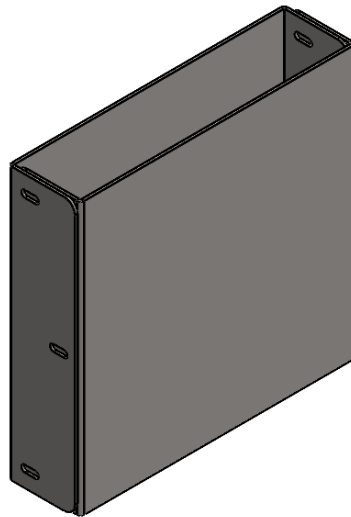

Figure 6 HEADER PROJECTION BRACKET PACKAGE

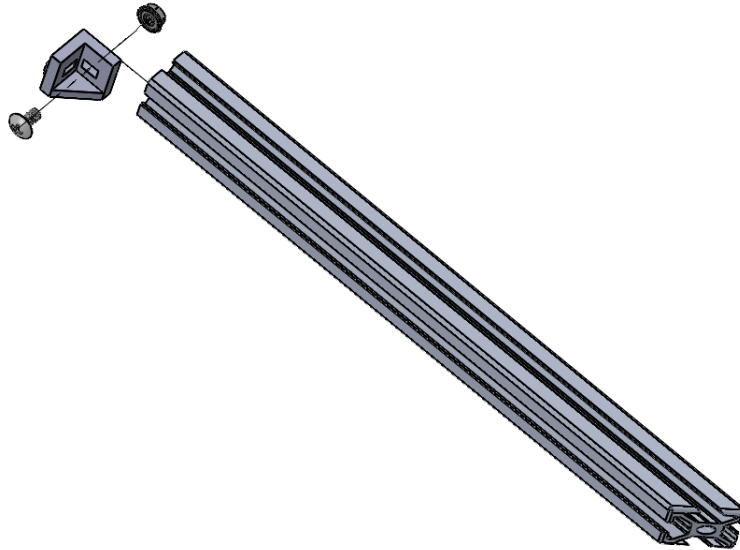

Figure 7 TRACK PROJECTION BRACKET COMPONENTS AND ARRANGEMENT

INSTALL HEADER PROJECTION BRACKETS

1. Hold Header Projection Mount Brackets at the wall markings. Orient it to fit between, and above, your markings on the wall. That is, with the flange facing outward, put the bottom edge on the height line, and the outer edge on your vertical overall width line. Trace the insides of its oval mounting slots onto the wall mount surface. (Figure 8 LOCATE/INSTALL HEADER OFFSET MOUNTING BRACKET)
2. Predrill through the centers of the traced locations for the mounting hardware, three (3) pilot holes on each side.
3. Using adequate mounting screws or bolts (depending on your building/surface material) attach the header offset brackets to each side of the opening. (Figure 8 LOCATE/INSTALL HEADER OFFSET MOUNTING BRACKET)

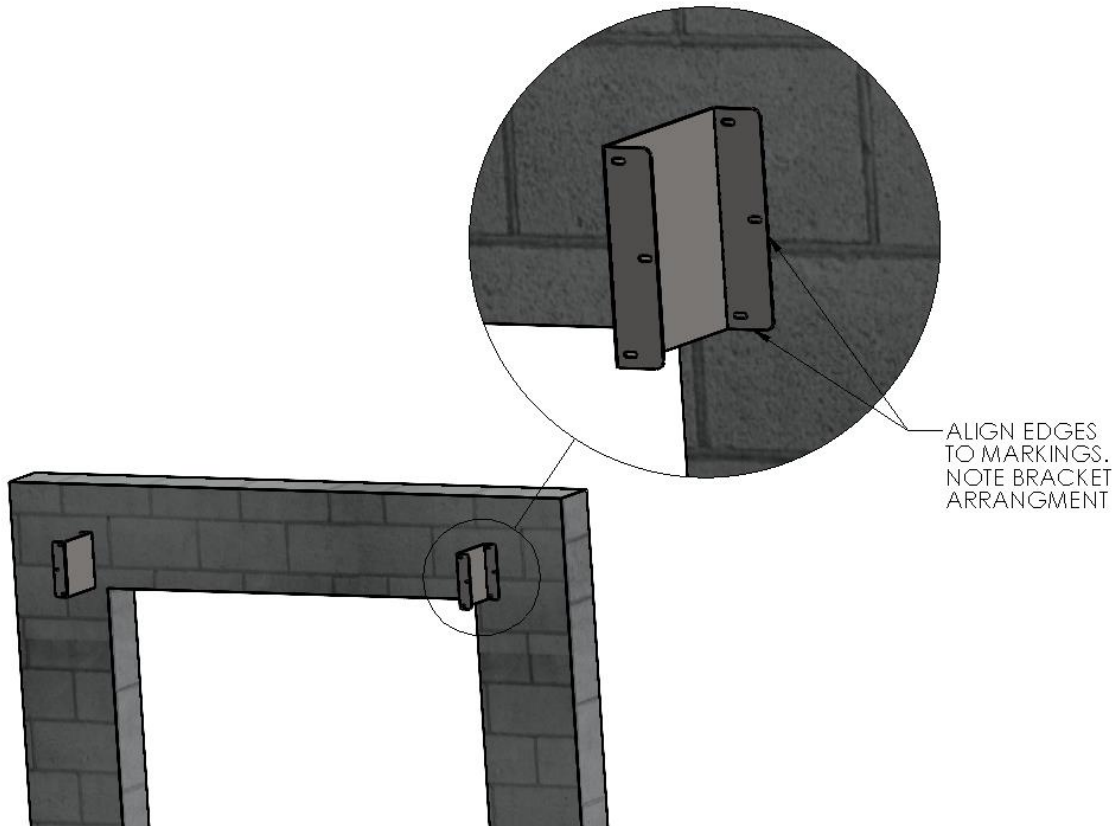

Figure 8 LOCATE/INSTALL HEADER OFFSET MOUNTING BRACKET

RAISE AND ATTACH THE ROLL HEADER ASSEMBLY

1. Using two (2) people, and two ladders at minimum, raise the Roll Header Assembly into place on the offset brackets and secure with three (3) sets of ¼-20 screws and hex nuts per side. Do not fully tighten hardware until the Header Assembly Brackets are aligned with the offset brackets/edges. (Figure 9 MOUNT HEADER ASSEMBLY TO OFFSET BRACKETS)
2. Once aligned, fully tighten all six sets of hardware. Check the Header Assembly for level, then make any necessary final adjustments.
3. At this point leave the roll assembly tied off and held in place as it comes.

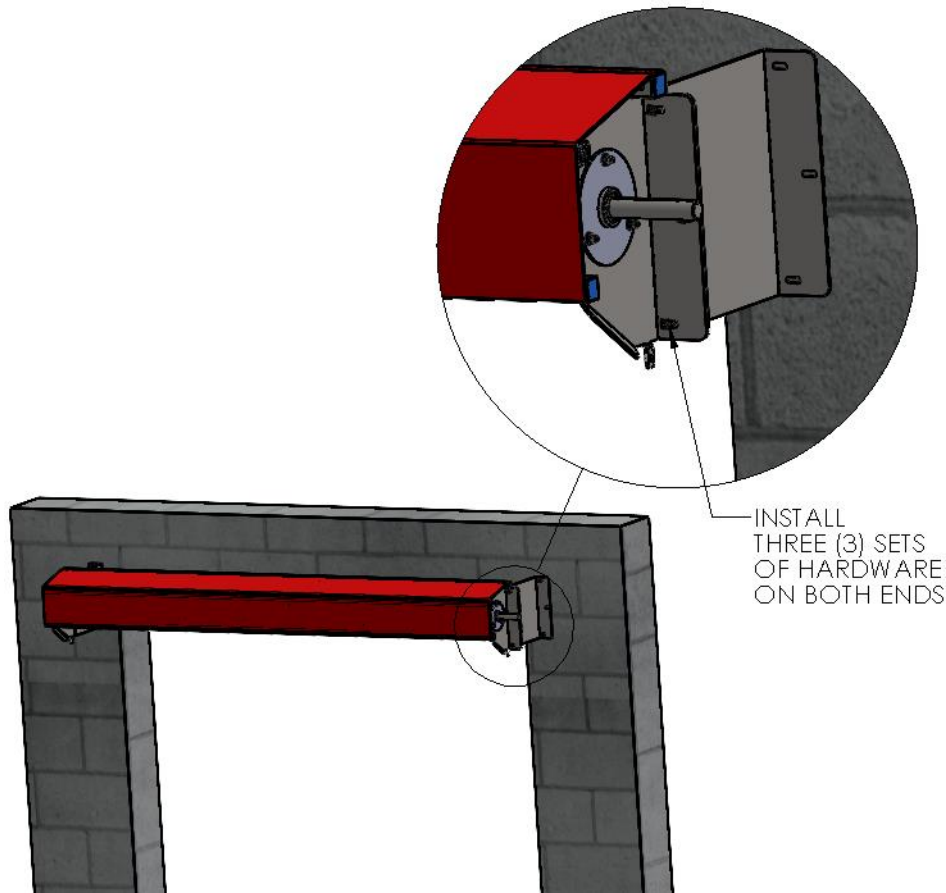

Figure 9 MOUNT HEADER ASSEMBLY TO OFFSET BRACKETS

PREPARE THE VERTICAL TRACK ASSEMBLIES

Note: The Track Assemblies are marked for orientation as Left side, and Right side.

1. Lay the two Vertical Track Assemblies on your work surface, and un-roll the Side Seal material.
2. Attach the Track Projection Brackets with the hardware provided. (Figure 10 TRACK PROJECTION BRACKET ARRANGEMENT)

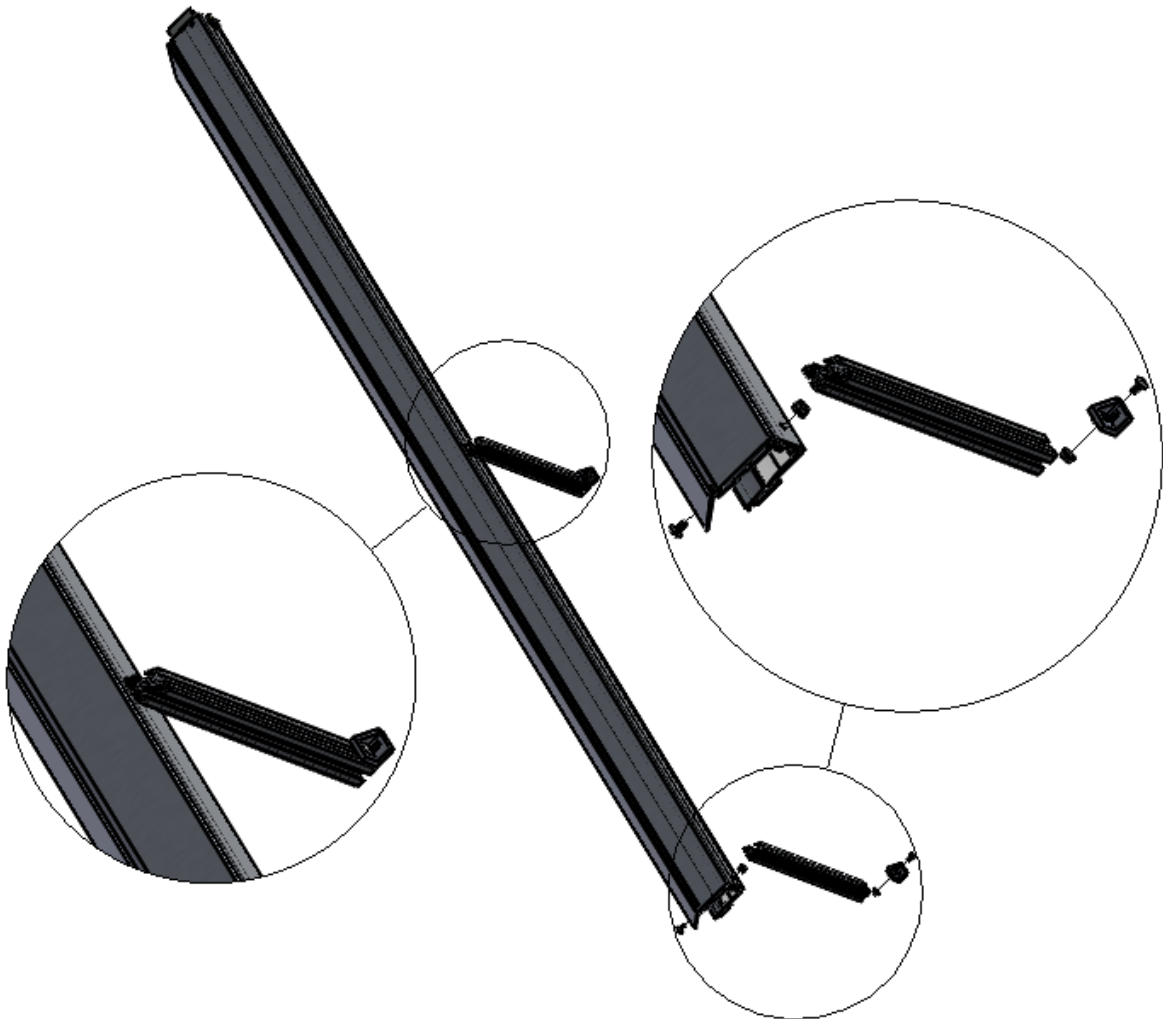

Figure 10 TRACK PROJECTION BRACKET ARRANGEMENT

MOUNT THE VERTICAL TRACKS

1. Align the square hole in the metal Transition Bracket of the Track Assembly with the square hole in the lower mounting tab on the Header Bracket. Insert the carriage bolt from the inside of the transition and the washer and hex nut on the outside of the assembly, as shown. Just snug this hardware for now. (Figure 11 MOUNT TRACK TO HEADER)
2. With the track “hanging” in this position, plumb the track to make sure it is vertically aligned, and that its Projection Brackets are touching the wall/mount surface. Usually with two people (one holding the track assembly in place), use a marker to trace the oval shaped mount holes on the wall to mark their pilot hole locations.

3. Move the track assembly off to the side and predrill its mounting holes. Move it back into place and secure it to the wall with appropriate hardware. Be sure to plumb each track and check vertical alignment before fully tightening hardware. The Track to Header Hardware will be removed and replaced in the next step, so snug them for now.

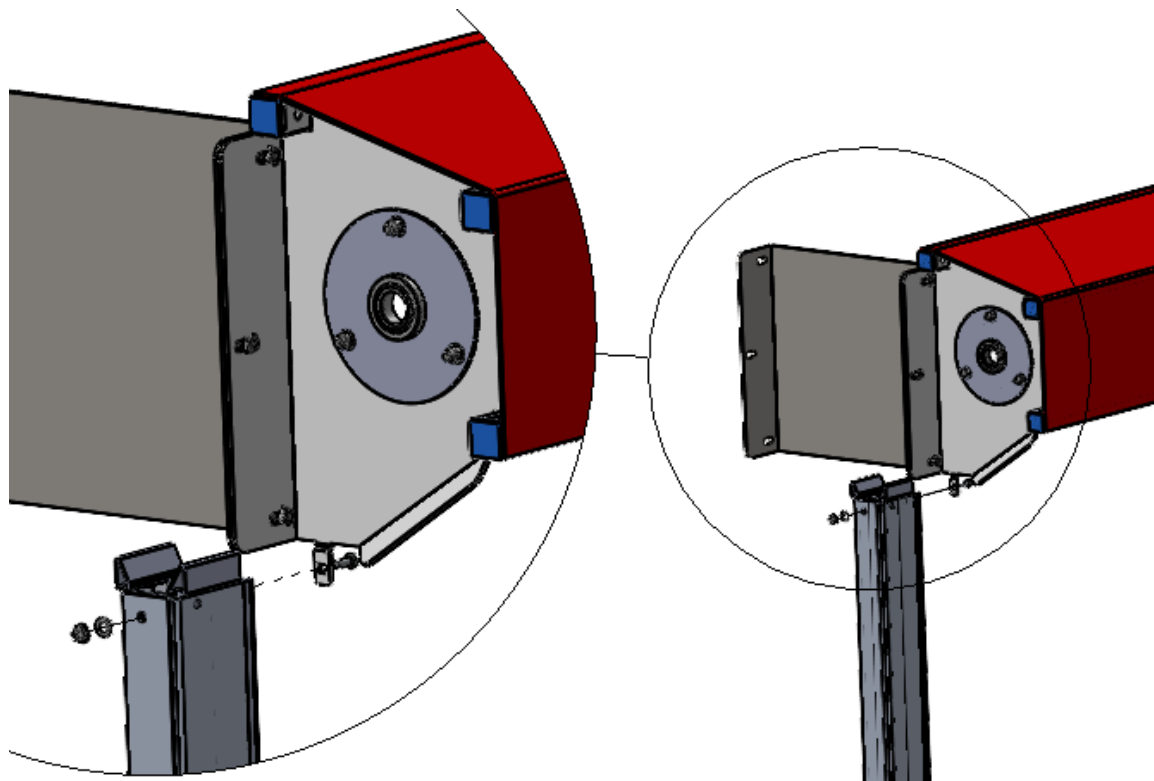

Figure 11 MOUNT TRACK TO HEADER

MOUNT THE SIDE SEAL

1. Remove the nut and washer from the Track Transition Bracket, then re-install them over the Side Seal Grommet. (Figure 12 SECURE SIDE SEAL)
2. Secure the top edge of the Side Seal to the Header Projection Brackets via the hook-and-loop strips provided in the hardware bag. (Figure 12 SECURE SIDE SEAL)
3. Fold the Side Seal Material to flatten it against the wall, then secure it through the material into the wall with appropriate screws. (Figure 12 SECURE SIDE SEAL)

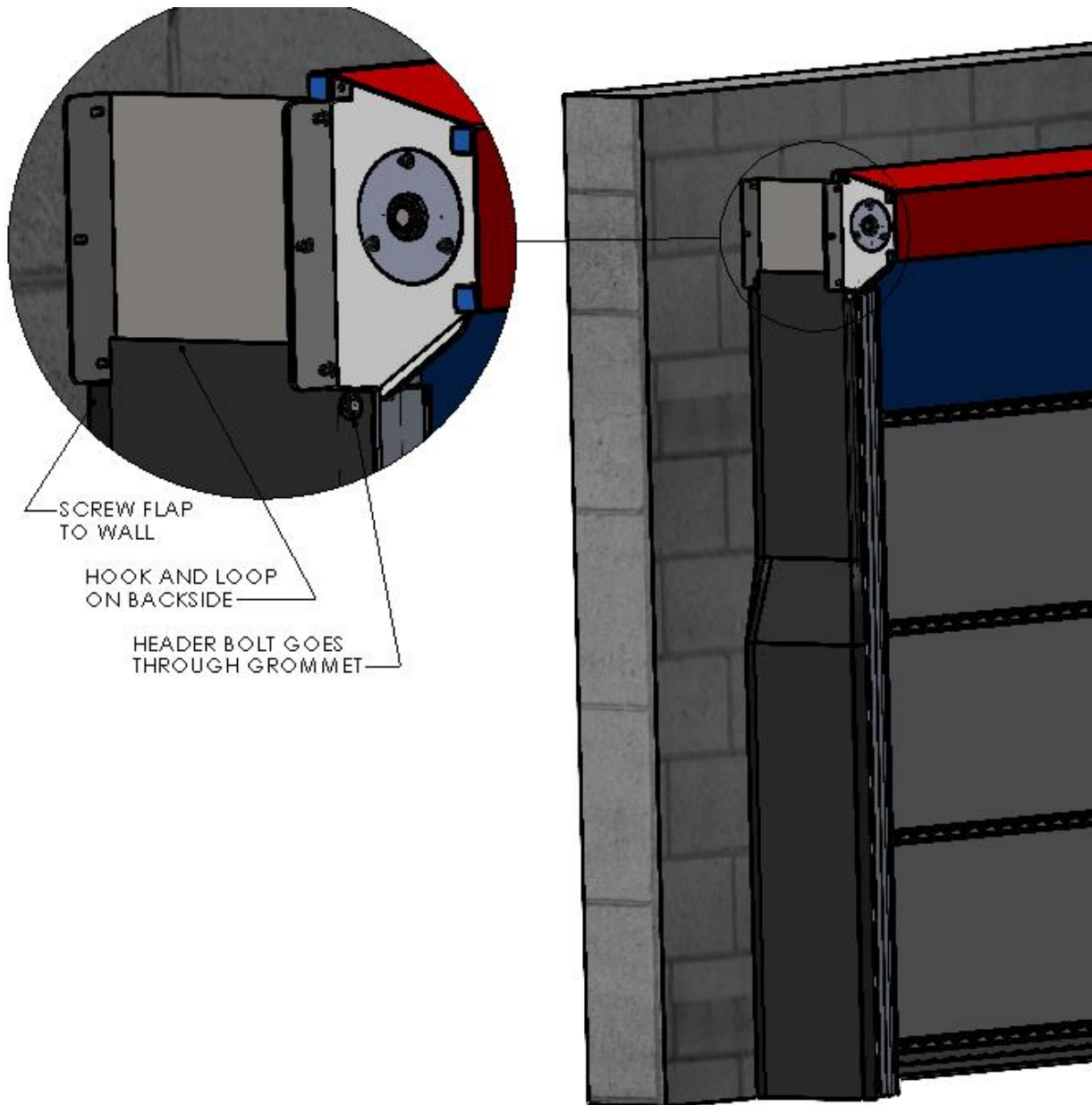

Figure 12 SECURE SIDE SEAL

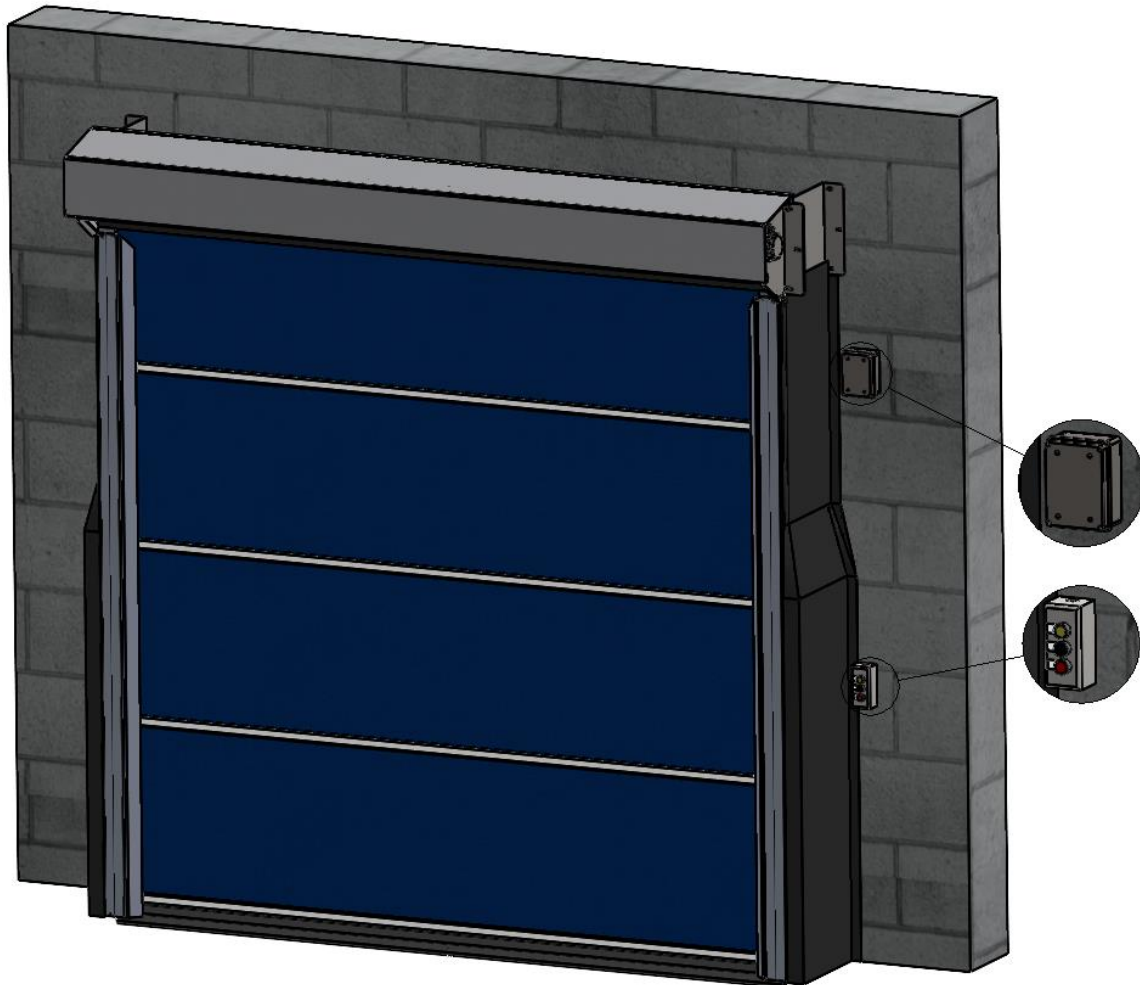

Figure 13 CONTROL BOX LOCATION

CHECK ALL MOUNTINGS AND CONNECT OPERATOR

1. With everything mounted, take a moment to check all of your hardware, and all of the components for horizontal and vertical alignments.
2. Release the ties on the roll assembly.
3. Have a qualified Electrician mount the Switch Control Box, route, and connect all wiring before applying power to the Door Assembly. (Figure 13 CONTROL BOX LOCATION)

NOTE - See supplemental Instruction for:
"Electrical Connections and Motor Adjustments".

WARNING

ALL INSTALLATION INSTRUCTIONS MUST BE FOLLOWED, AND CRITICAL ALIGNMENT REQUIREMENTS MUST BE MET.

- ENSURE THAT THE ROLL HEADER ASSEMBLY IS LEVEL, AND THAT THE TRACKS AND BRACKETS ARE ALL PLUMB, AND SQUARE-

OTHERWISE, THE PERFORMANCE AND CONSISTENT OPERATION OF YOUR DOOR WILL BE COMPROMISED.

LIMITED WARRANTY

G2 1800 Doors



Goff's Enterprises, Inc. warrants all G1 bug screen/vinyl doors from failure in normal use due to defects in material or workmanship for a period of **THREE years** from date of purchase with warranty related labor for the three years as approved by Goff's Technical Support Team. Goff's Enterprises, Inc. may elect to repair or replace defective or damaged goods. **Technical Support Team: 262-746-3374**