

G1 PLUS SERIES – FLUSH MOUNTED COMMERCIAL VINYL DOOR INSTALLATION INSTRUCTIONS

READ THIS MANUAL CAREFULLY. OBSERVE WARNINGS AND PRACTICE CAUTION WHEN INSTALLING, OPERATING, OR MAINTAINING YOUR GOFF'S DOOR ASSEMBLY.

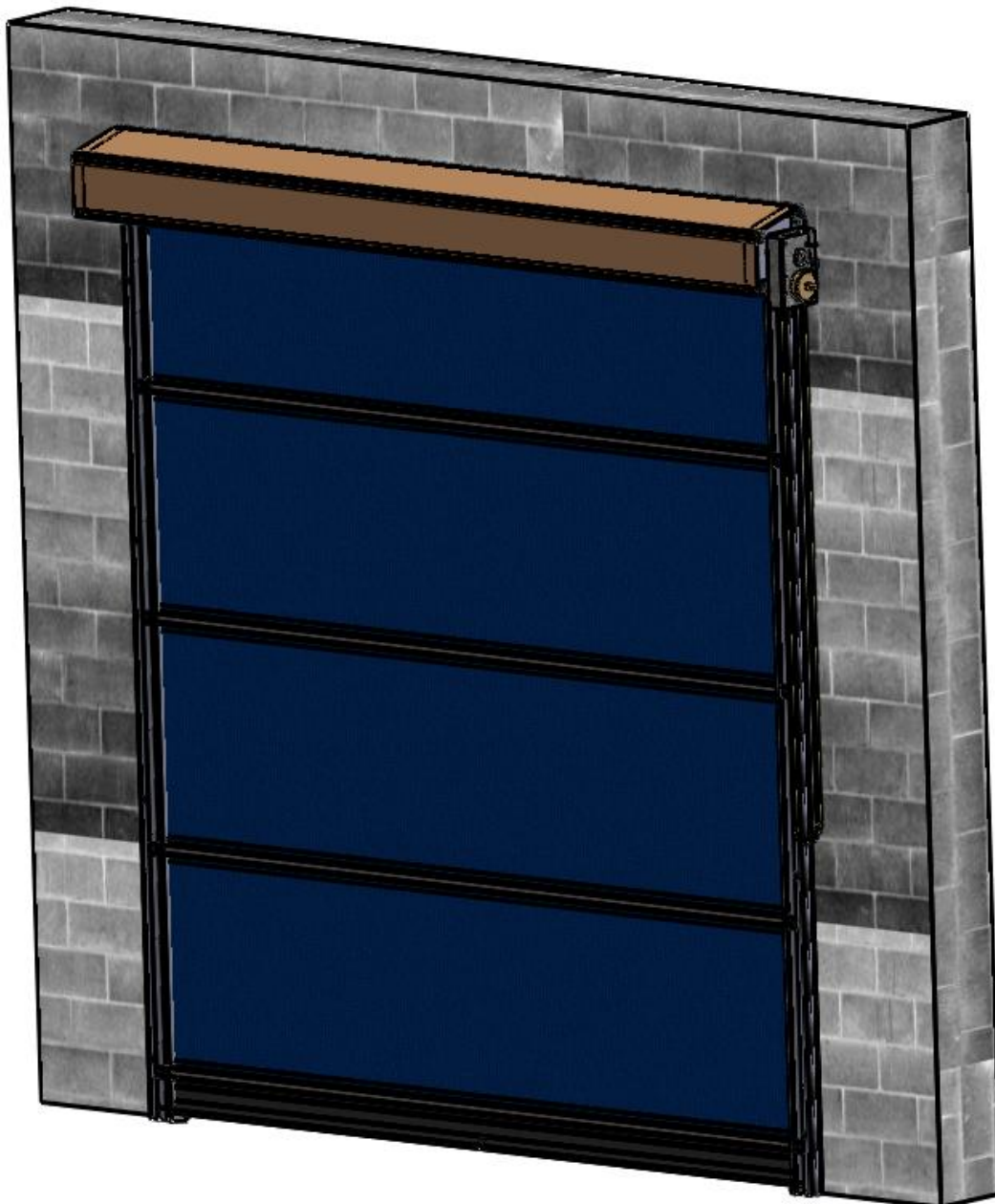

PREPARE MOUNTING SURFACE AND LOCATE HEADER ASSEMBLY

1. Measure the existing door width at the opening or frame from the outermost edges on each side near the top of the opening. Divide that overall width measurement in half to find and clearly mark the center of the top of the door frame or its header. (Figure 1 MEASURE/MARK OPENING)
2. Place the G1 Door roll Header Assembly across a safe and level work surface, and rotate the roll assembly frame so that the Header Bracket Mounting flanges are facing upward. (Figure 2 MEASURE DOOR WIDTH).
3. Measure the total width of the whole roll assembly from outermost edge of one Header Bracket's Mounting flange to the outermost edge of the opposite side. (Figure 2 MEASURE DOOR WIDTH)
4. Divide that number by 2, and measure to each side of the center mark in step 1. Mark a vertical line at these locations. This is where the outer edges of the Header Bracket's Mounting flanges will be. (Figure 3 MARK DOOR WIDTH ON WALL)
5. Set one of the Vertical Track Assemblies on your work surface and measure the length of the vinyl Track only. ADD 3-1/4" to this number and take note. This is the height dimension needed to mark the location of the bottom edge of the Header Mounting Brackets. With this number, add a horizontal line on each side of the opening that intersects the previously drawn vertical line marking the overall width of the roll assembly. (Figure 4 MEASURE TRACK HEIGHT) (Figure 5 MARK TRACK HEIGHT)
6. Using two (2) people, and two ladders at minimum, raise the Header Assembly to fit between, and below, your markings on the wall. Trace the insides of its oval mounting slots onto the wall mount surface (a Sharpe permanent marker works great for this). Be sure that its top edge is on the height line, and that the outer edge is on your vertical overall width line.
7. Pre-drill through the centers of the traced locations for the mounting hardware, three (3) pilot holes on each side.

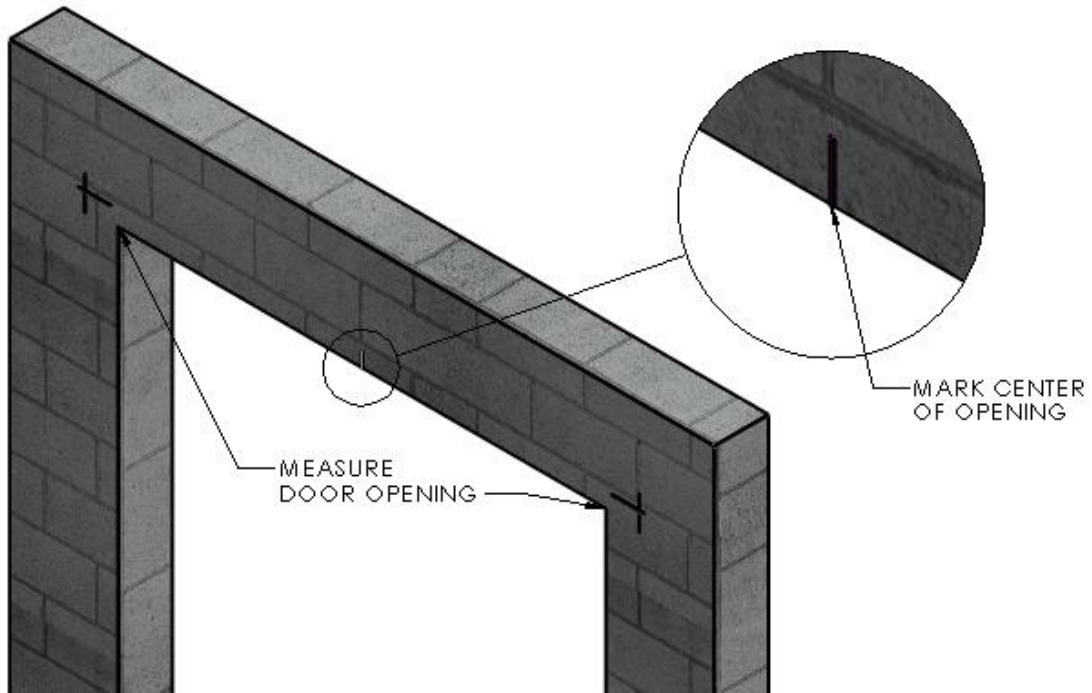

Figure 1 MEASURE/MARK OPENING

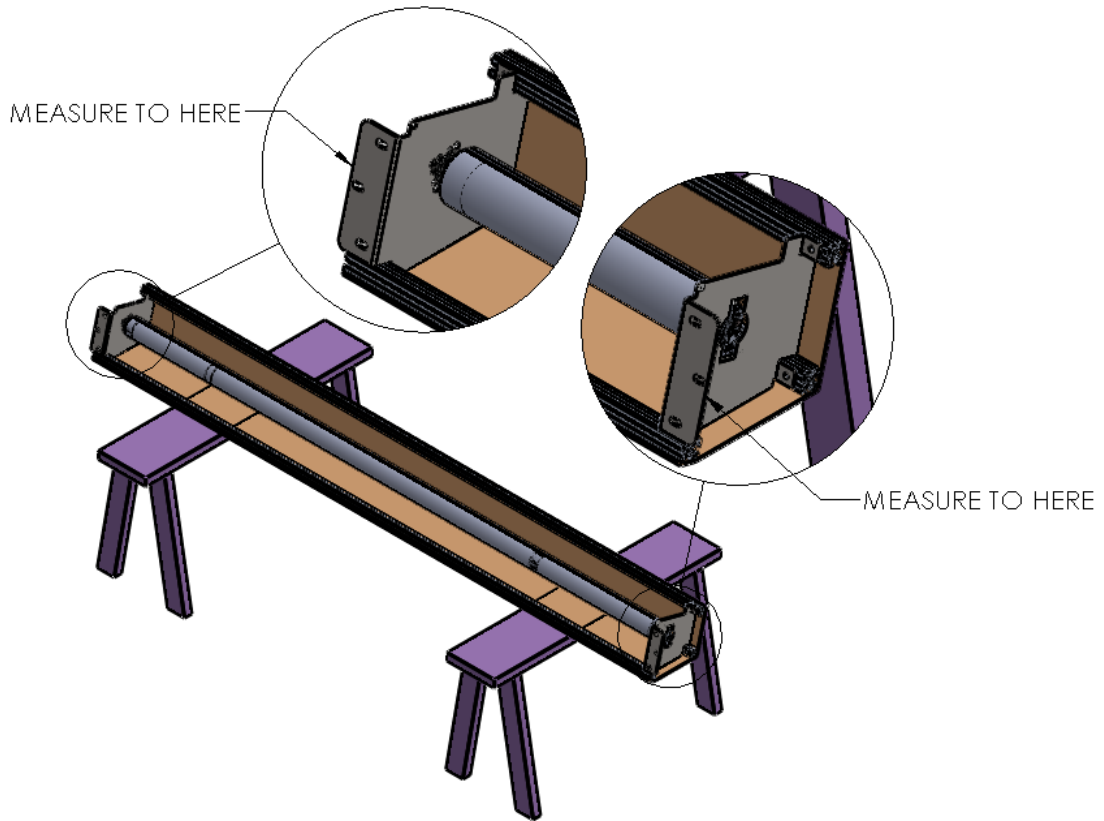

Figure 2 MEASURE DOOR WIDTH

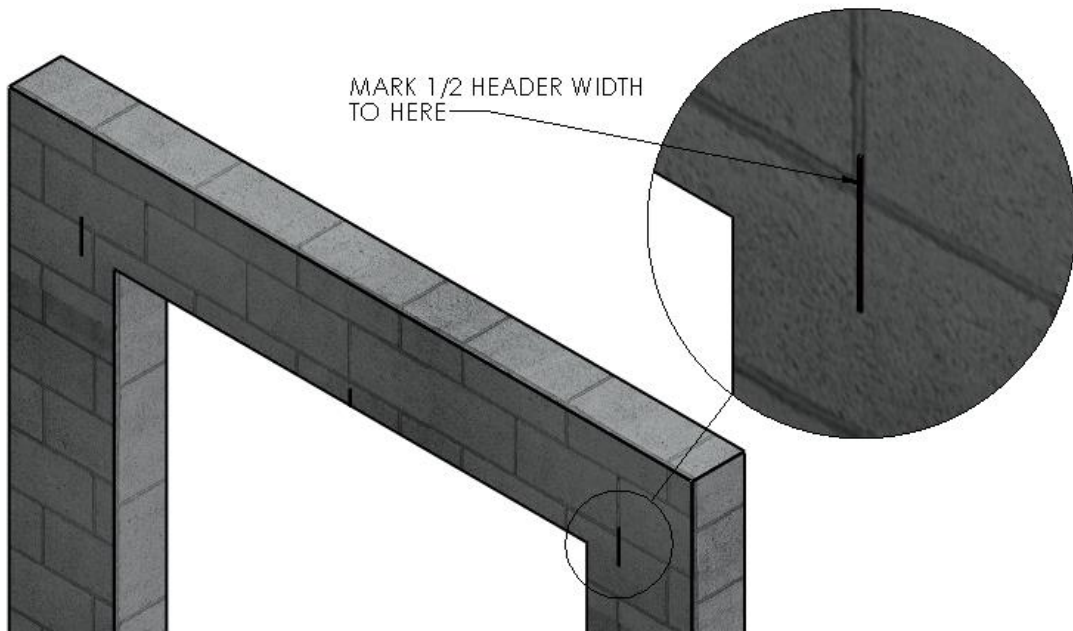

Figure 3 MARK DOOR WIDTH ON WALL

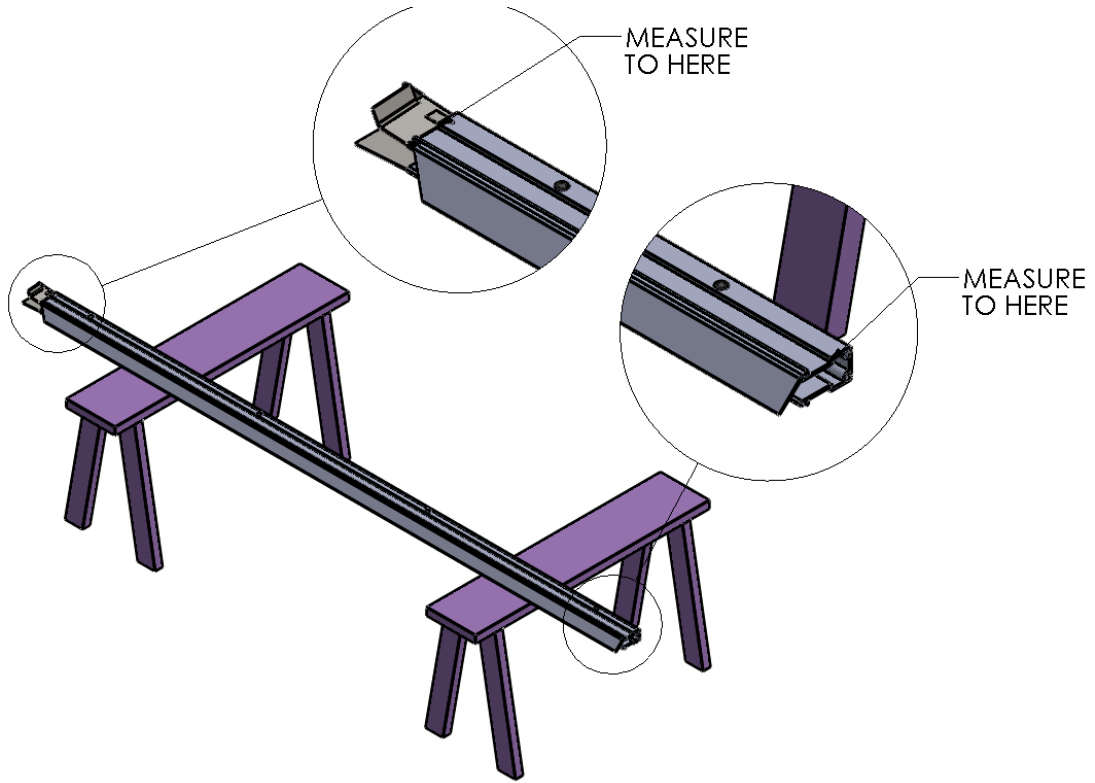

Figure 4 MEASURE TRACK HEIGHT

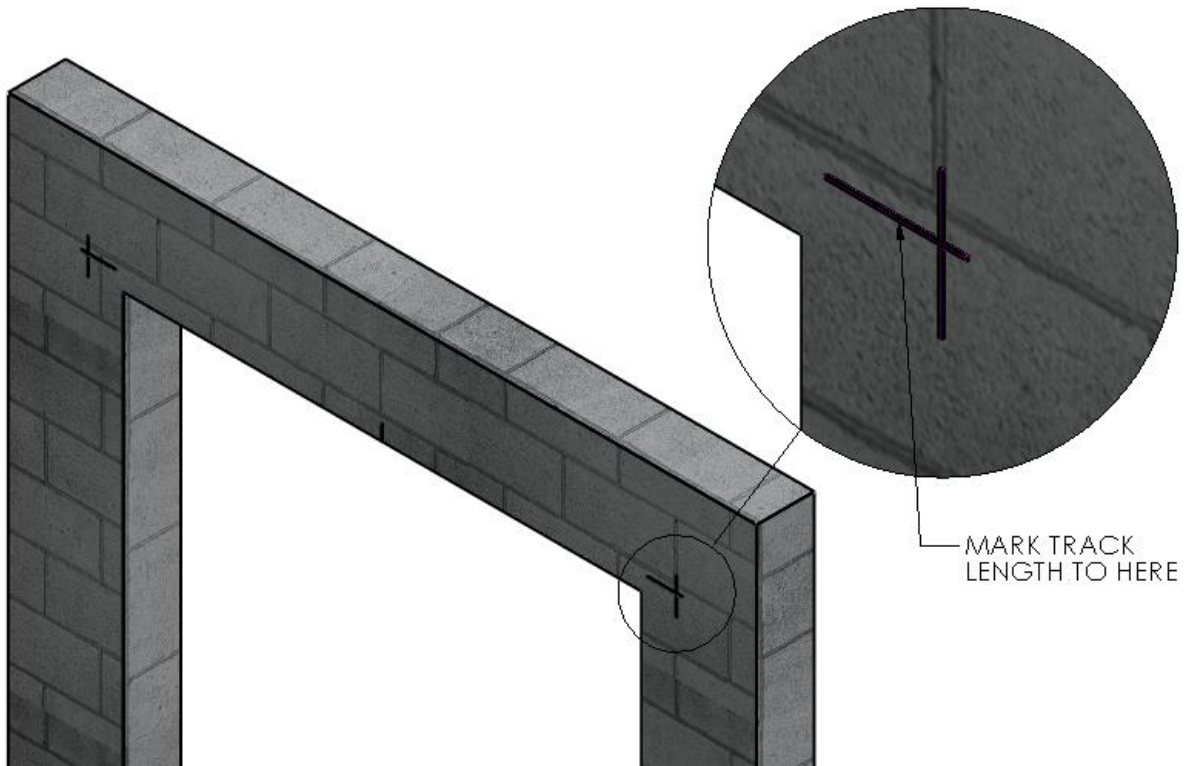

Figure 5 MARK TRACK HEIGHT

RAISE AND ATTACH THE ROLL HEADER ASSEMBLY

1. Using two (2) people, and two ladders at minimum, raise the Roll Header Assembly into place on the wall, and loosely secure with three (3) sets of mounting hardware per side - screws or bolts, adequate to your building/surface material. (Figure 6 MOUNT HEADER ASSEMBLY TO WALL)
2. Check the Header Assembly for level, and fully tighten all six sets of hardware.
3. At this point leave the roll assembly tied off and held in place as it comes.

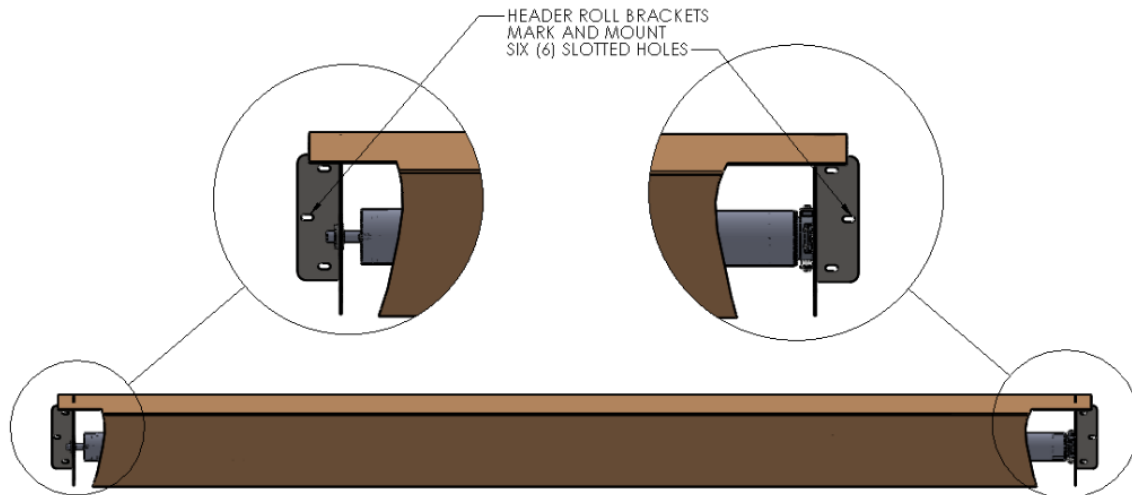

Figure 6 MOUNT HEADER ASSEMBLY TO WALL

MOUNT THE VERTICAL TRACKS

1. Starting with either the left or right side, loosely “hang” the Track Assembly by its Transition Bracket Mount hardware. Note that the transition Bracket mounts to the inside of the tab of the Header Assembly Mounting Bracket. It is important to insert the carriage bolt from the inside of the transition and the washer and hex nut on the outside of the assembly as shown. (Figure 8 MOUNT TRACK TO HEADER)
2. With the Track Assembly “hanging” in this position, plum the Track to make sure it is vertically aligned. Usually with two people (one holding the track assembly in place), use a marker on the wall to mark their pilot hole locations.
3. Move the Track Assembly off to the side and predrill its mounting holes. Move it back into place and secure it to the wall with appropriate hardware. Before fully tightening hardware, be sure to each track is plumb/vertical.



Figure 7 TRACK MOUNTING HARDWARE

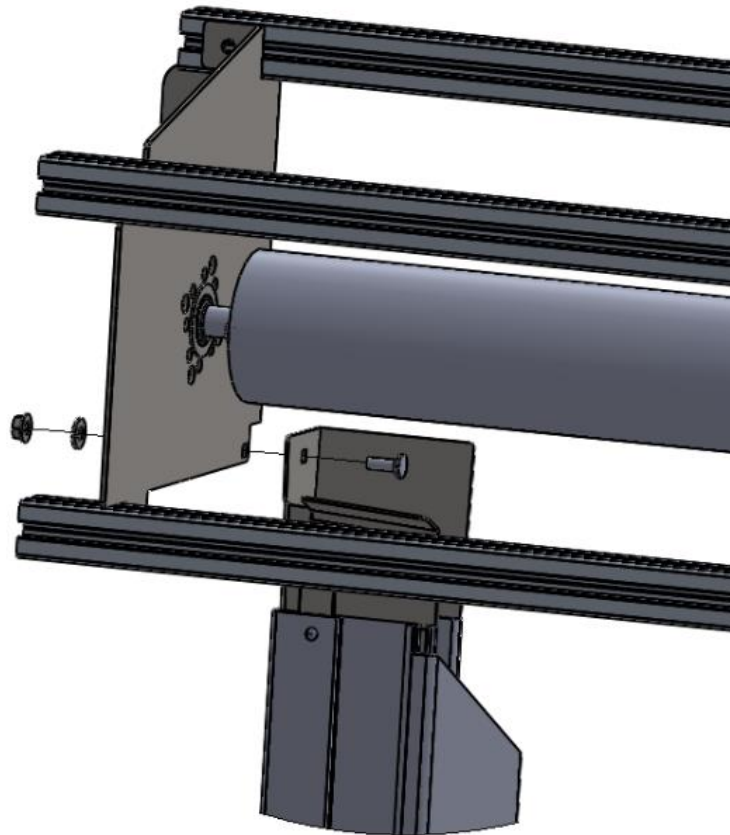
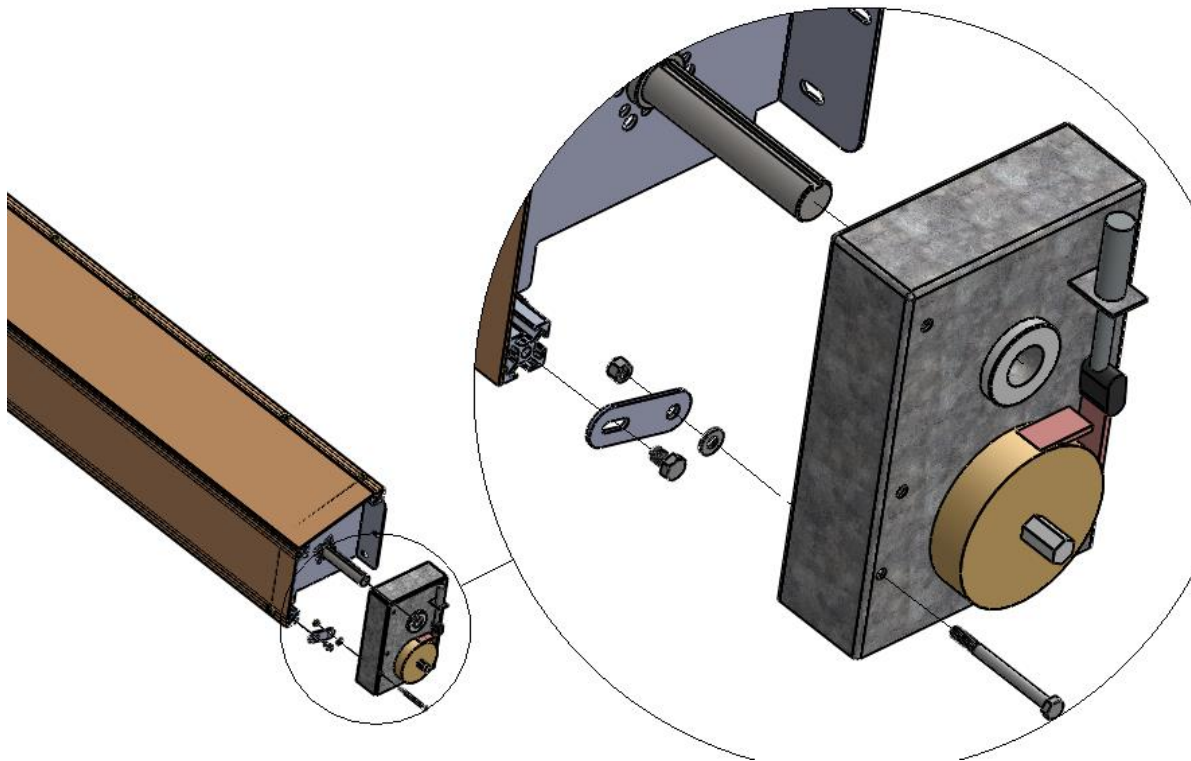

Figure 8 MOUNT TRACK TO HEADER

CHECK ALL MOUNTINGS AND INSTALL OPERATOR

1. With everything mounted, take a moment to check all of your hardware, and all of the components for horizontal and vertical alignments.
2. Insert the provided 1/4" Sq. Key stock into the Chain Hoist Key Way, and slip the Chain Hoist Operator onto the 1" Dia. Drive Shaft.
3. Insert the 3" long Hex Bolt through the width of the Chain Hoist Operator, through the washer and flat Bracket, and secure with the Nylon Hex Nut.
4. Secure the Hex Bolt through the flat Bracket, and into the end of the Aluminum Extrusion.
5. Release the ties on the roll assembly.



WARNING

ALL INSTALLATION INSTRUCTIONS MUST BE FOLLOWED, AND CRITICAL ALIGNMENT REQUIREMENTS MUST BE MET.

- ENSURE THAT THE ROLL HEADER ASSEMBLY IS LEVEL, AND THAT THE TRACKS AND BRACKETS ARE ALL PLUMB, AND SQUARE-

OTHERWISE, THE PERFORMANCE AND CONSISTENT OPERATION OF YOUR DOOR WILL BE COMPROMISED.

LIMITED WARRANTY

G1 Bug Screen/Vinyl Doors



Goff's Enterprises, Inc. warrants all G1 bug screen/vinyl doors from failure in normal use due to defects in material or workmanship for a period of **TWO years** from date of purchase with warranty related labor for the first year as approved by Goff's Technical Support Team.

Goff's Enterprises, Inc. may elect to repair or replace defective or damaged goods.

Technical Support Team: 262-746-3374