

G1 SERIES – UNDER HEADER MOUNTED COMMERCIAL VINYL DOOR INSTALLATION INSTRUCTIONS

READ THIS MANUAL CAREFULLY. OBSERVE WARNINGS AND PRACTICE CAUTION WHEN INSTALLING, OPERATING, OR MAINTAINING YOUR GOFF'S DOOR ASSEMBLY.

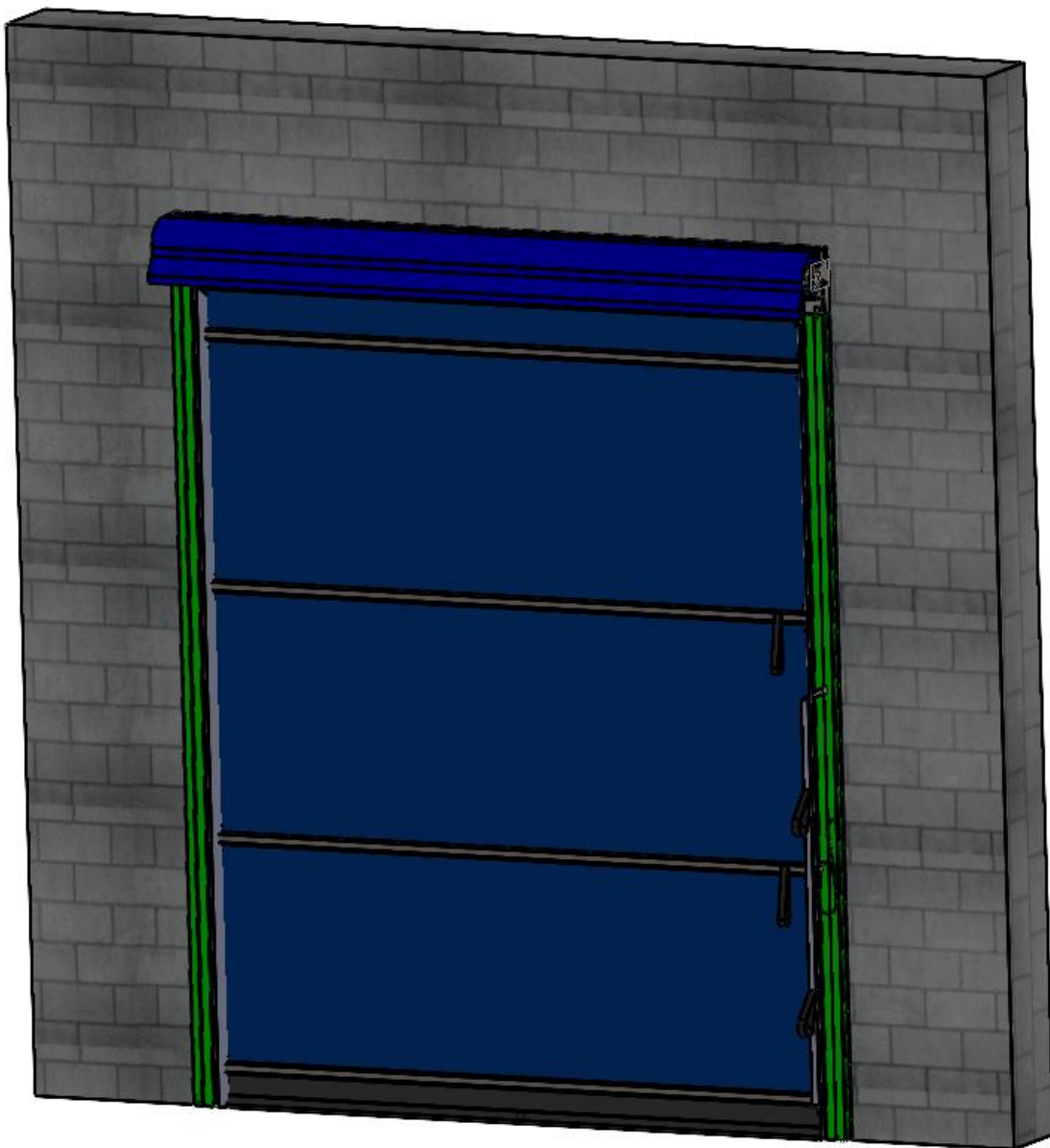

PREPARE MOUNTING SURFACE AND SECURE MAIN HEADER BRACKETS

Note: Check the Door Opening Header for level, and adjust the installation accordingly.

1. At the upper left of the door opening, use the L.H. Header Mounting Bracket to transfer hole locations to the mounting surface.(Figure 1 LOCATE L.H.HEADER MOUNTING BRACKET) & (Figure 2 MARK/DRILL L.H. HEADER MOUNTING BRACKET)
2. Insert your Wall Mounting Hardware through Idler Bearing assembly (3 pieces), and through the L.H. Header Mounting Bracket, into the Mounting Surface. (Figure 3 INSTALL HEADER BRACKET AND IDLER ASSEMBLY)
3. At the upper right of the opening, use the R.H. Header Mounting Bracket to transfer the hole locations to the mounting surface, and install this bracket. (Figure 4 MOUNT SPRING HEADER BRACKET)

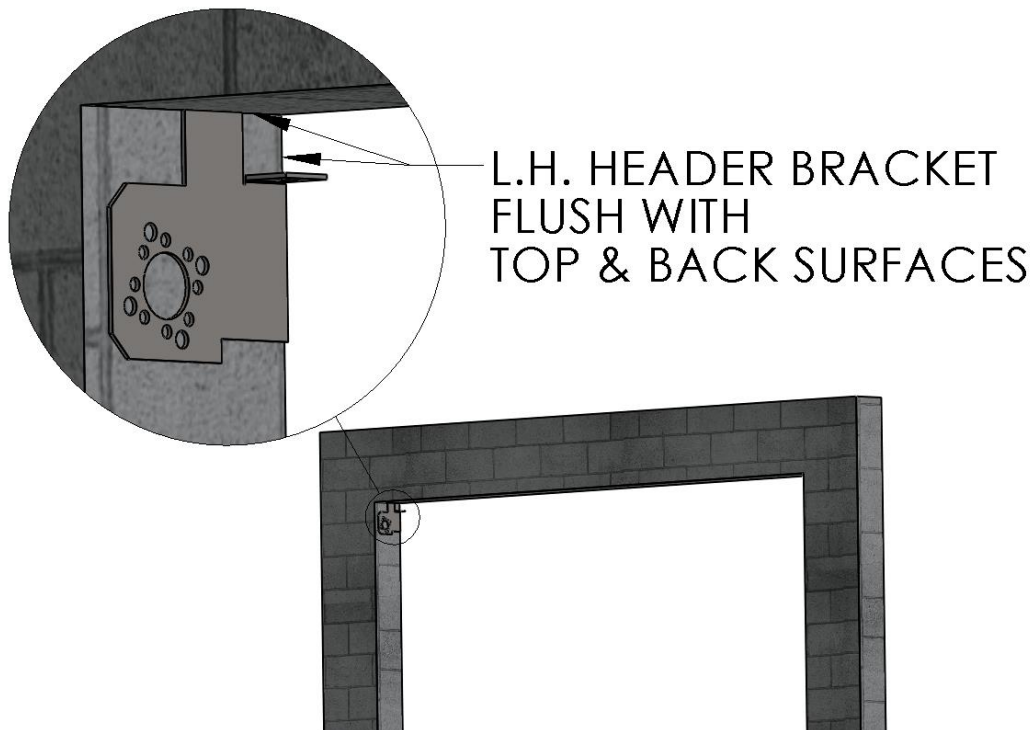

Figure 1 LOCATE L.H.HEADER MOUNTING BRACKET

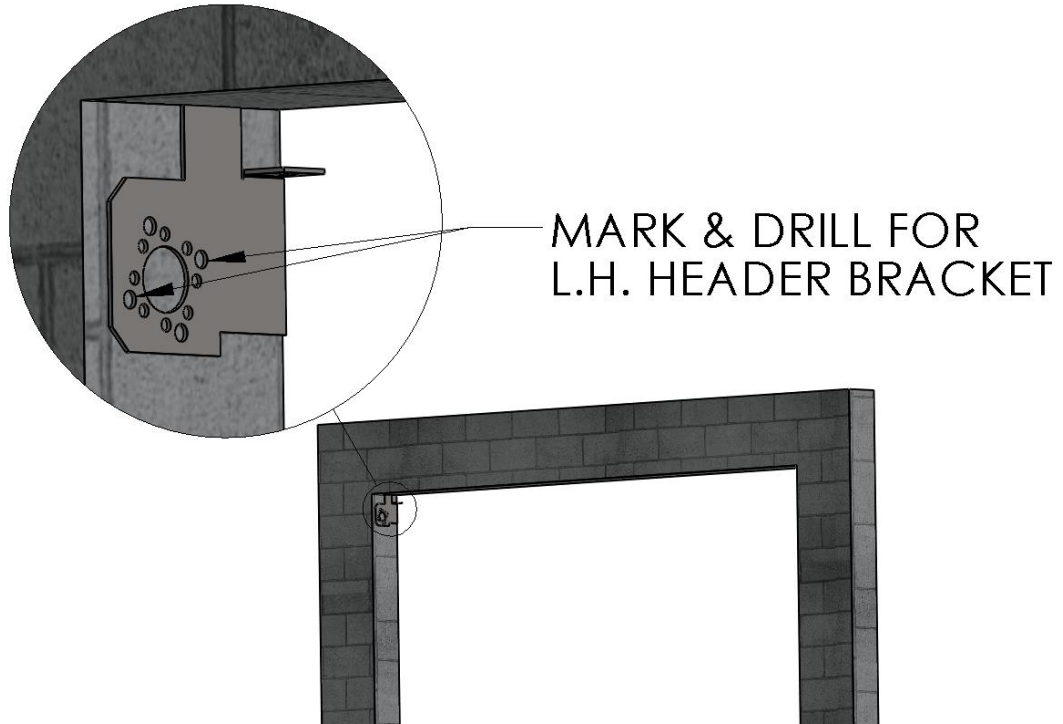

Figure 2 MARK/DRILL L.H. HEADER MOUNTING BRACKET

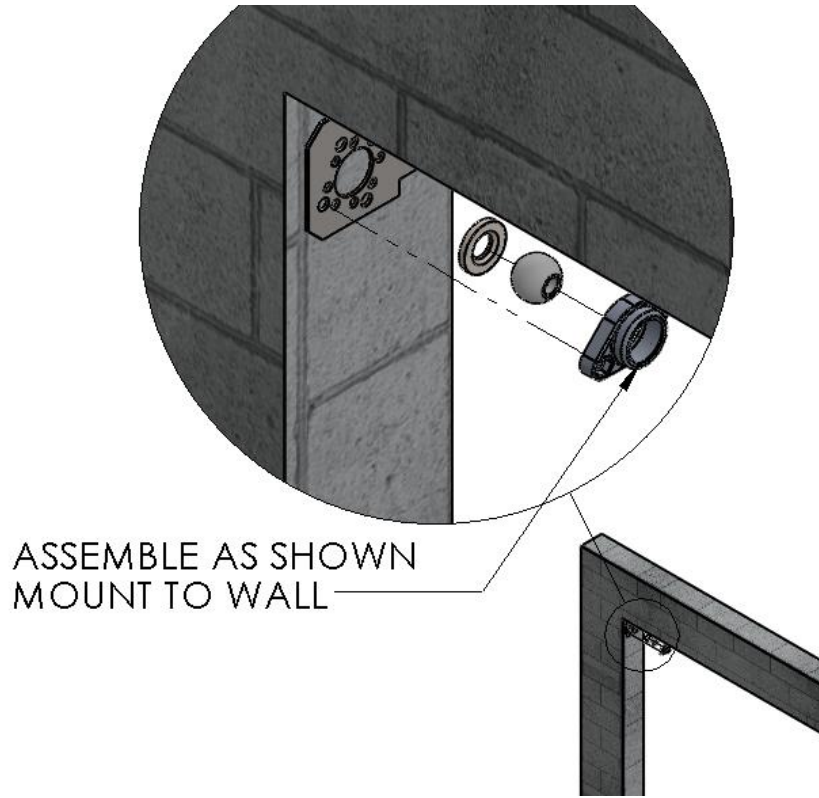

Figure 3 INSTALL HEADER BRACKET AND IDLER ASSEMBLY

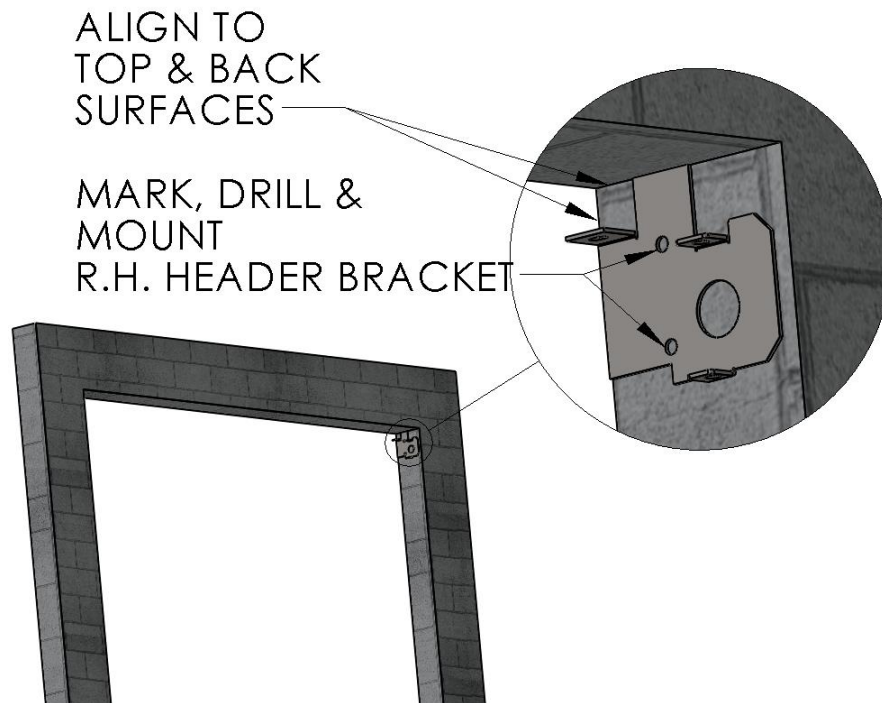

Figure 4 MOUNT SPRING HEADER BRACKET

MOUNT THE VERTICAL TRACKS

1. To locate the Track Assemblies, align the mating surfaces of the Track Transition Bracket and the Header Mounting Bracket. (Figure 5 LOCATE, MARK, INSTALL TRACK ASSEMBLIES)
2. Plumb Track Assembly, to make sure it is vertically aligned. Usually with two people (one holding the Track Assembly in place), use a marker to trace the mounting holes on the wall to mark their pilot hole locations.
3. Move the track assembly off to the side and predrill its mounting holes. Move it back into place and secure it to the wall with appropriate hardware. Before fully tightening hardware, be sure each track is plumb/vertical.
4. Repeat for the other Track Assembly.

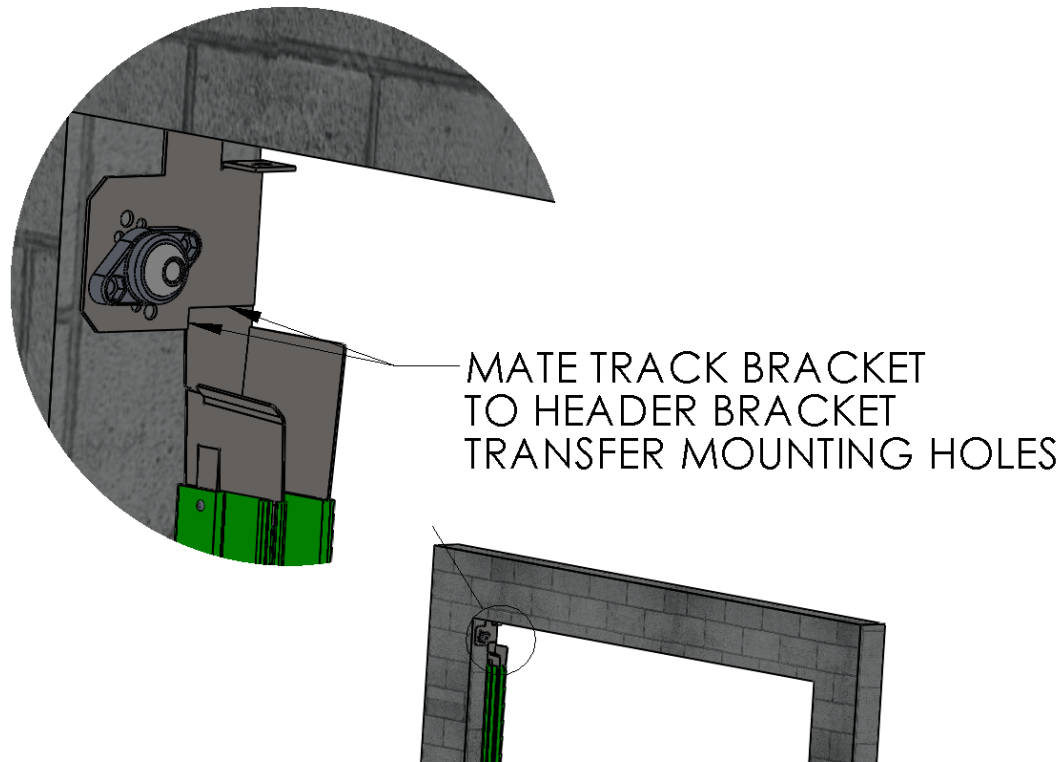

Figure 5 LOCATE, MARK, INSTALL TRACK ASSEMBLIES

MOUNT THE HEADER ASSEMBLY

1. Using two (2) people, and two ladders at minimum, raise the Header Assembly, and insert the Idler Shaft into the installed Idler Bearing Assembly at upper left. (Figure 6 INSTALL L.H. SIDE OF HEADER ASSEMBLY)
2. At the right side, push the Header Assembly toward the Idler side to compress (spring loaded) Idler Shaft, and insert the Nylon Block, oriented vertically, into Wall Mounting Bracket and install the bolts and washers to secure the Block to the Wall Mounting Bracket. (Figure 7 INSTALL R.H. SIDE OF HEADER ASSEMBLY)
3. At this point leave the roll assembly tied off and held in place as it comes.

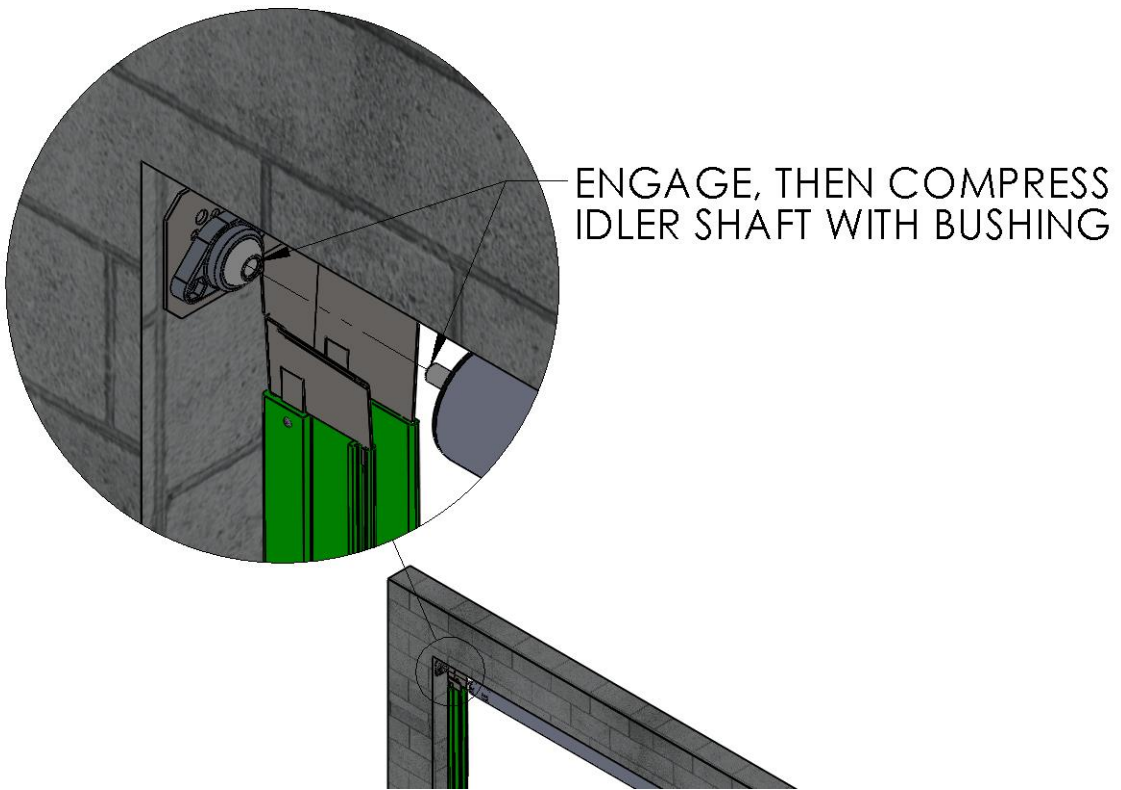

Figure 6 INSTALL L.H. SIDE OF HEADER ASSEMBLY

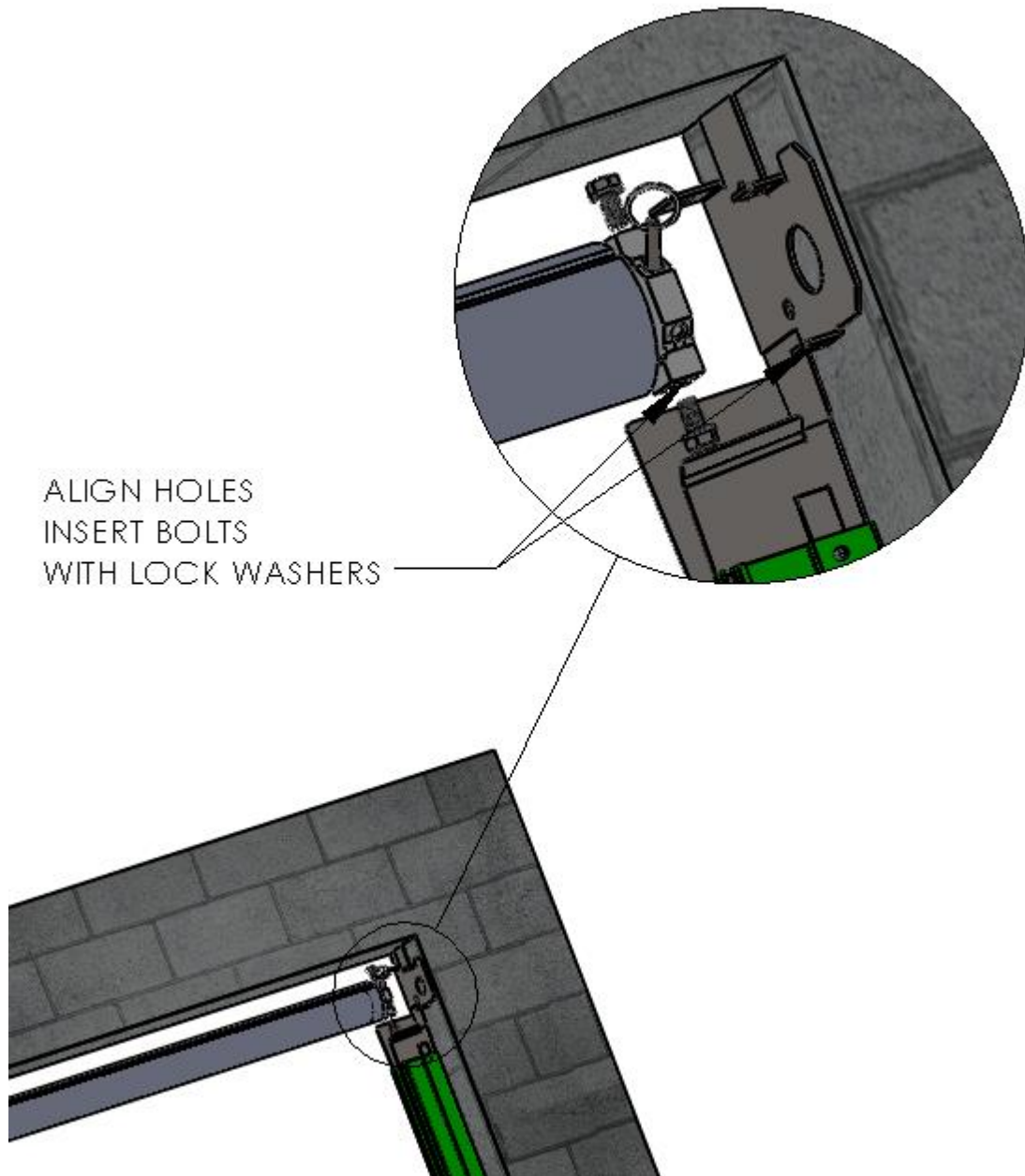

Figure 7 INSTALL R.H. SIDE OF HEADER ASSEMBLY

MOUNT THE VALANCE ASSEMBLY

1. Install the Valance Assembly onto the top of the bent flanges of the installed Header Mounting Brackets using the hardware provided in the Wall mounting Brackets. (Figure 8 INSTALL VALANCE ASSEMBLY)

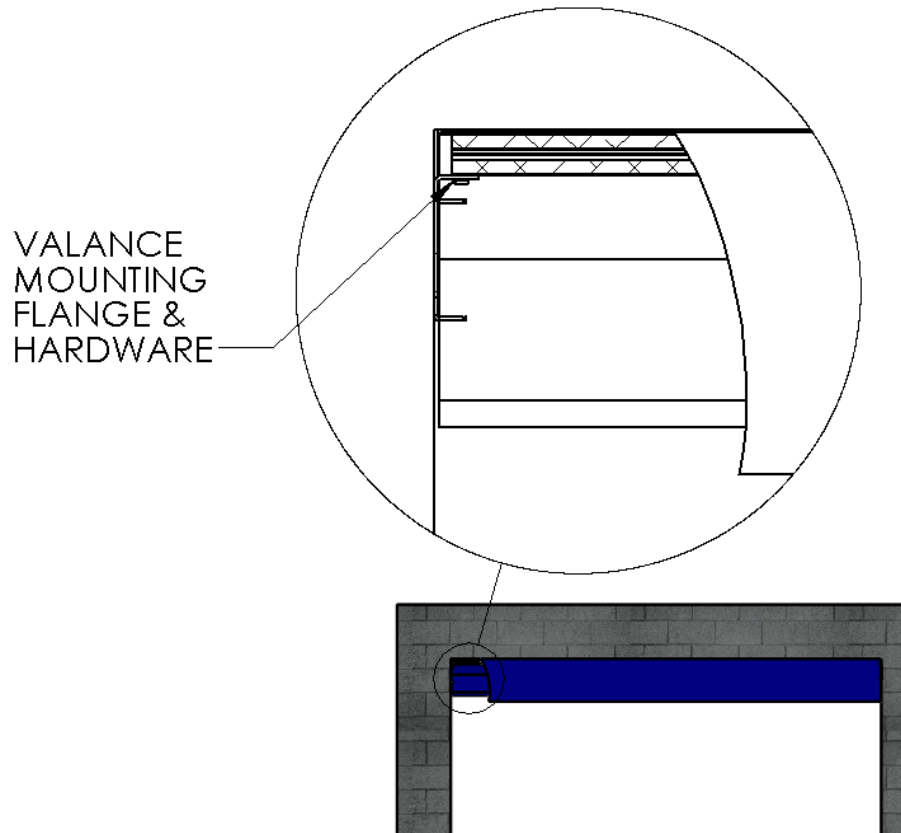

Figure 8 INSTALL VALANCE ASSEMBLY

CHECK ALL MOUNTINGS

1. With everything mounted, take a moment to check all of your hardware, and all of the components for horizontal and vertical alignments.

SECURE PULL STRAP AND ADJUST SPRING OPERATOR

1. Use the Buckle provided to secure the long Pull Strap to the mounting Bracket attached to the Right-Side Track. (Figure 9 SECURE PULL STRAP)
2. Adjust the length to set the upper Stop Point of the Door.

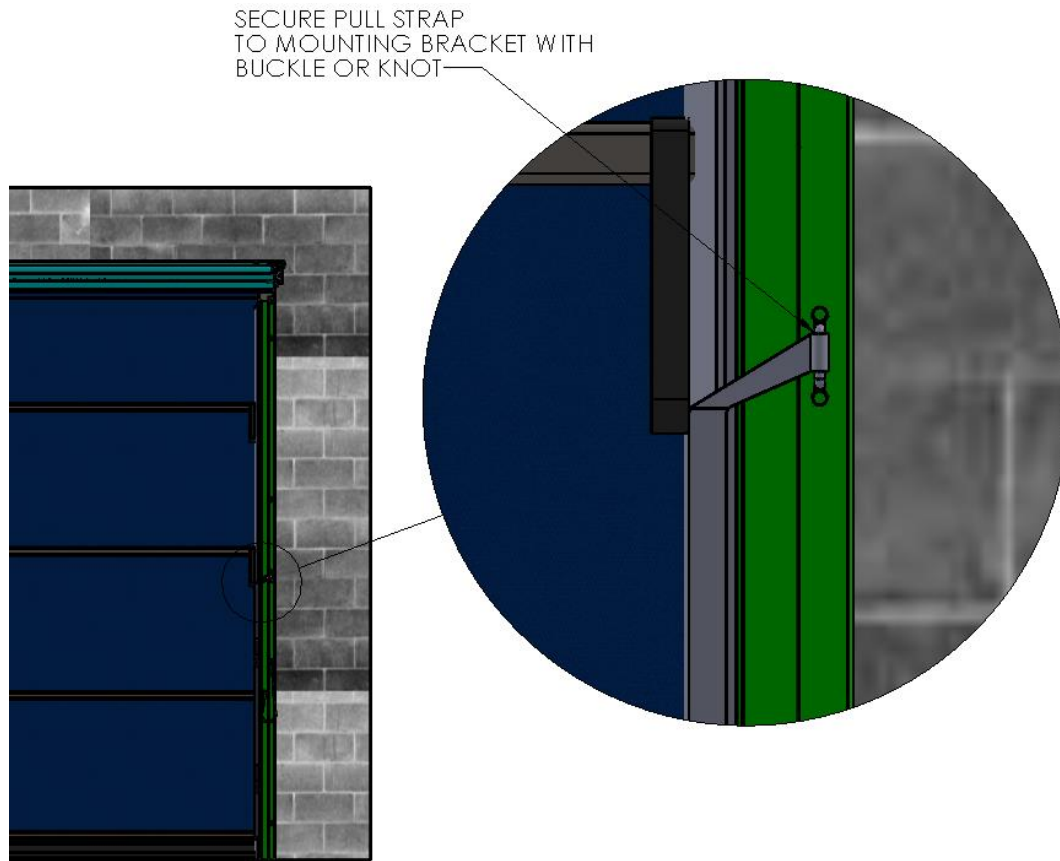

Figure 9 SECURE PULL STRAP

NOTE: Spring tension is maintained either with a 1/2" open-end wrench on the wrench flats, or with the Quick-Release pin.

1. Spring tension is increased/decreased with a two-step process. To increase spring tension, insert the open-end wrench onto the wrench flats, then pull the Quick-Release pin. Pull the wrench down (CCW) until the pin can be replaced – about a quarter turn. Repeat this two-step process about 8 times equaling about 2 full turns on the spring. (Figure 10 WRENCH FLATS/SPRING TENSIONING PIN)
2. Release the ties on the roll assembly.
3. Use the Pull Straps to pull the door down to the closed position.
4. Release the straps to open the door, and note the upper stop point. Adjust by increasing/decreasing the tension 1 quarter turn, and test again.

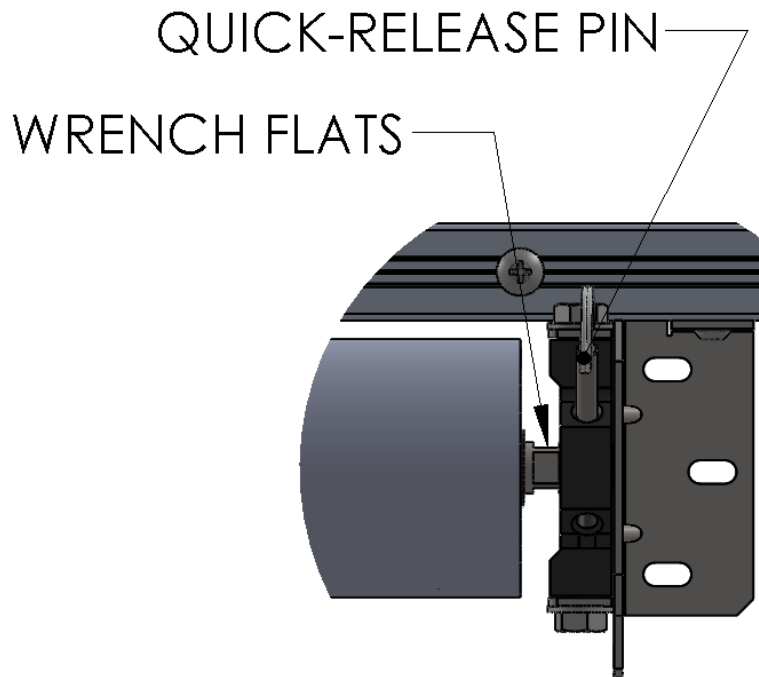

Figure 10 WRENCH FLATS/SPRING TENSIONING PIN

INSTALL THE LOCK PIN LANYARD

NOTE: The top edge of the second lowest Wind Bar of the Door will be where the Lock Pin meets and holds the Door in the closed position. A factory-cut notch is located in the Door Panel, on the right-hand side, to allow the Lock Pin to pass through the Door.

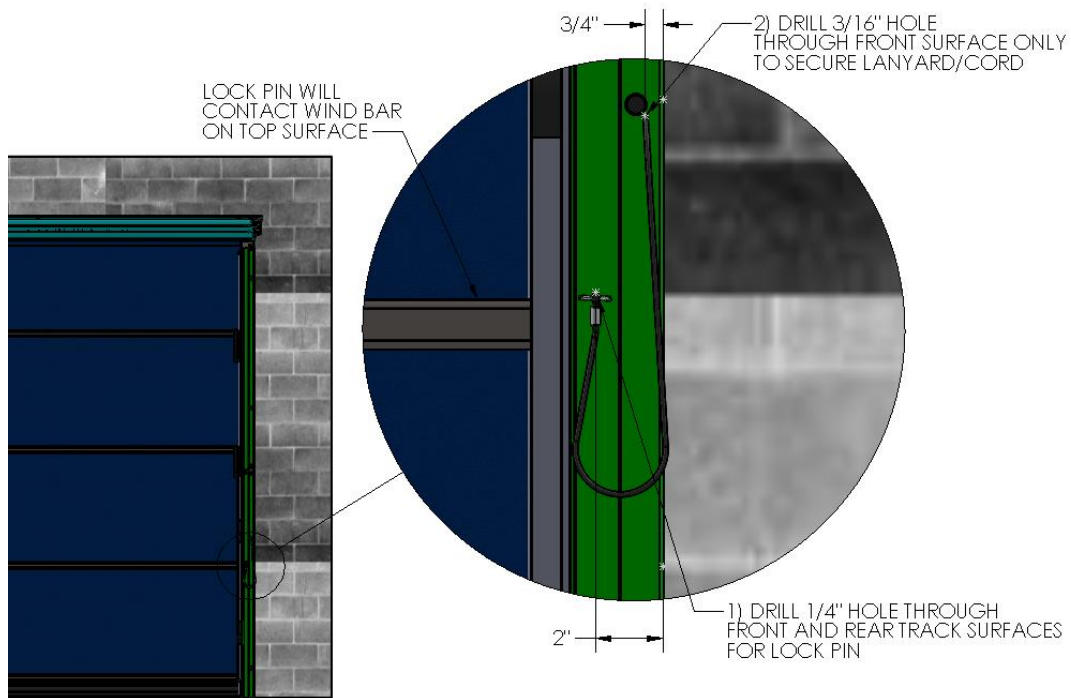

Figure 11 SPRING PIN DETAIL

1. Pull the door down/closed until a satisfactory seal with the floor is achieved
2. Mark the location of the top edge of the second lowest Wind Bar onto the Right-Hand vertical Track.
3. Release the Pull Strap to allow the door to return to the Open Position.
4. Drill a 1/4" Dia. hole through both legs of the track 2" from the right (outside of the track) which intersects your line.
5. Drill a 3/16" hole, a few inches above the 1/4" hole, at about 3/4" from the right (outside of the Track).
6. Insert the Lanyard/cord through this hole, and tie a knot on that end.
7. Pull the Door down to the closed position, and insert the Lock-Pin above the Wind Bar through the front and rear holes.

WARNING

ALL INSTALLATION INSTRUCTIONS MUST BE FOLLOWED, AND CRITICAL ALIGNMENT REQUIREMENTS MUST BE MET.

- ENSURE THAT THE ROLL HEADER ASSEMBLY IS LEVEL, AND THAT THE TRACKS AND BRACKETS ARE ALL PLUMB, AND SQUARE-

OTHERWISE, THE PERFORMANCE AND CONSISTENT OPERATION OF YOUR DOOR WILL BE COMPROMISED.

LIMITED WARRANTY

G1 Bug Screen/Vinyl Doors



Goff's Enterprises, Inc. warrants all G1 bug screen/vinyl doors from failure in normal use due to defects in material or workmanship for a period of **TWO years** from date of purchase with warranty related labor for the first year as approved by Goff's Technical Support Team.

Goff's Enterprises, Inc. may elect to repair or replace defective or damaged goods.

Technical Support Team: 262-746-3374