

G1 SERIES – FLUSH MOUNTED COMMERCIAL VINYL DOOR INSTALLATION INSTRUCTIONS

READ THIS MANUAL CAREFULLY. OBSERVE WARNINGS AND PRACTICE CAUTION WHEN INSTALLING, OPERATING, OR MAINTAINING YOUR GOFF'S DOOR ASSEMBLY.

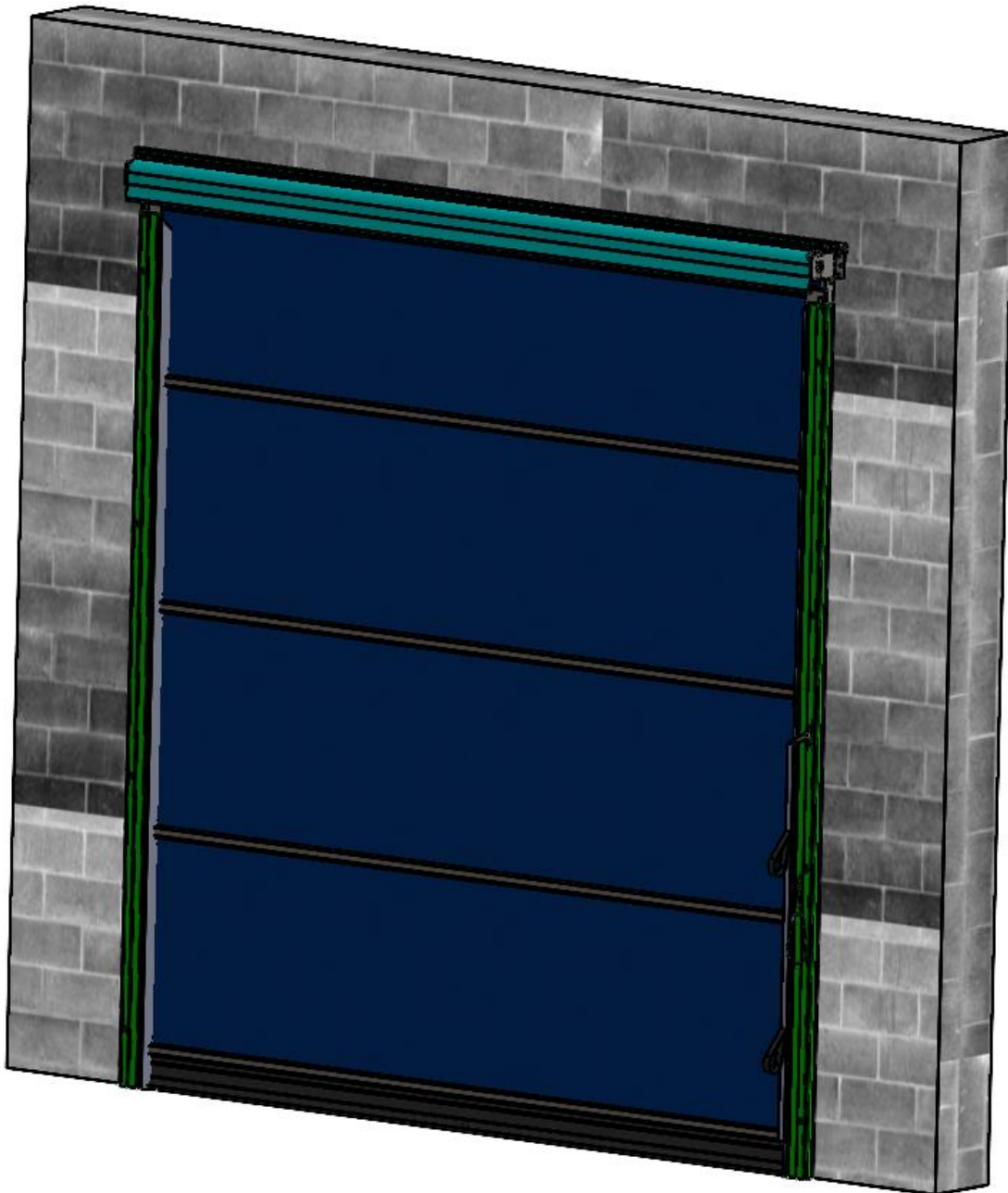

PREPARE MOUNTING SURFACE AND LOCATE HEADER ASSEMBLY

1. Measure the existing door width at the opening or frame from the outermost edges on each side near the top of the opening. Divide that overall width measurement in half to find and clearly mark the center of the top of the door frame or its header. (Figure 1 MEASURE/MARK OPENING)
2. Place the G1 Door roll Header Assembly across a safe and level work surface, and rotate the roll assembly frame so that the Header Bracket Mounting flanges are facing upward. (Figure 2 MEASURE DOOR WIDTH).
3. Measure the total width of the whole roll assembly from outermost edge of one Header Bracket's Mounting flange to the outermost edge of the opposite side. (Figure 2 MEASURE DOOR WIDTH)
4. Divide that number by 2, and measure to each side of the center mark in step 1. Mark a vertical line at these locations. This is where the outer edges of the Header Bracket's Mounting flanges will be. (Figure 3 MARK DOOR WIDTH ON WALL)
5. Set one of the Vertical Track Assemblies on your work surface and measure the length of the vinyl Track only. ADD 7-1/4" to this number and take note. This is the height dimension needed to mark the location of the top edge of the Header Mounting Brackets. With this number, add a horizontal line on each side of the opening that intersects the previously drawn vertical line marking the overall width of the roll assembly. (Note: This mark should be 7-1/2" above the opening height.) (Figure 4 MEASURE TRACK HEIGHT) (Figure 5 MARK TRACK HEIGHT)
6. Using two (2) people, and two ladders at minimum, raise the Header Assembly to fit between, and below, your markings on the wall. Trace the insides of its oval mounting slots onto the wall mount surface (a Sharpe permanent marker works great for this). Be sure that its top edge is on the height line, and that the outer edge is on your vertical overall width line.
7. Predrill through the centers of the traced locations for the mounting hardware, three (3) pilot holes on each side.

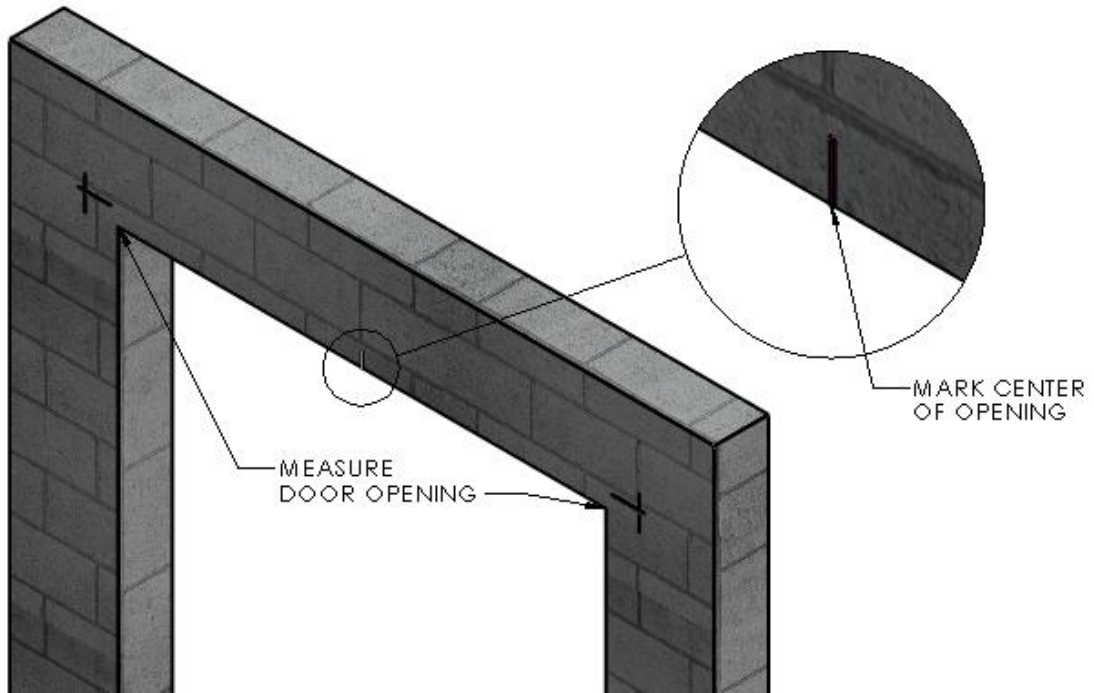

Figure 1 MEASURE/MARK OPENING

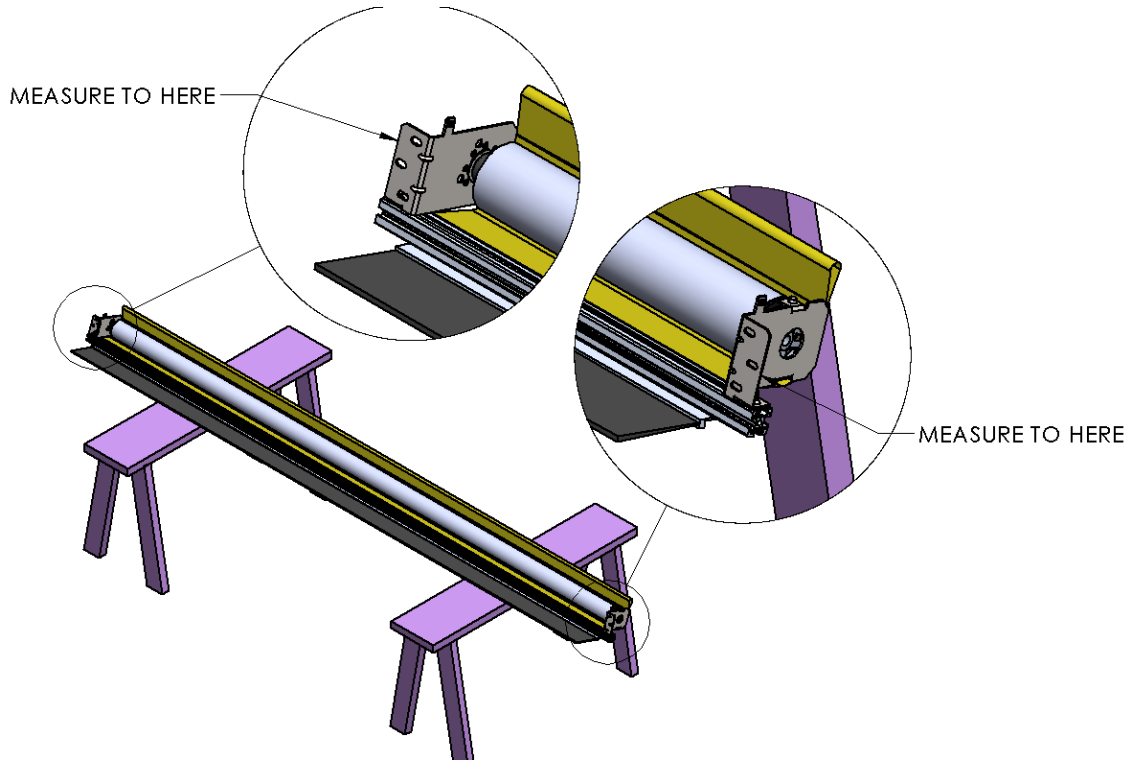

Figure 2 MEASURE DOOR WIDTH

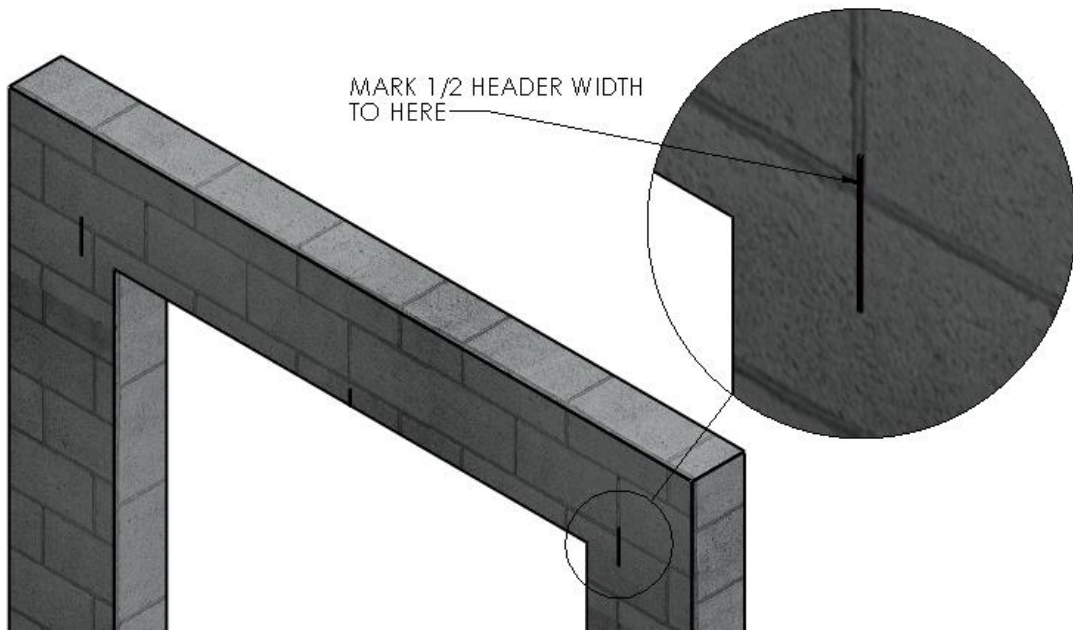

Figure 3 MARK DOOR WIDTH ON WALL

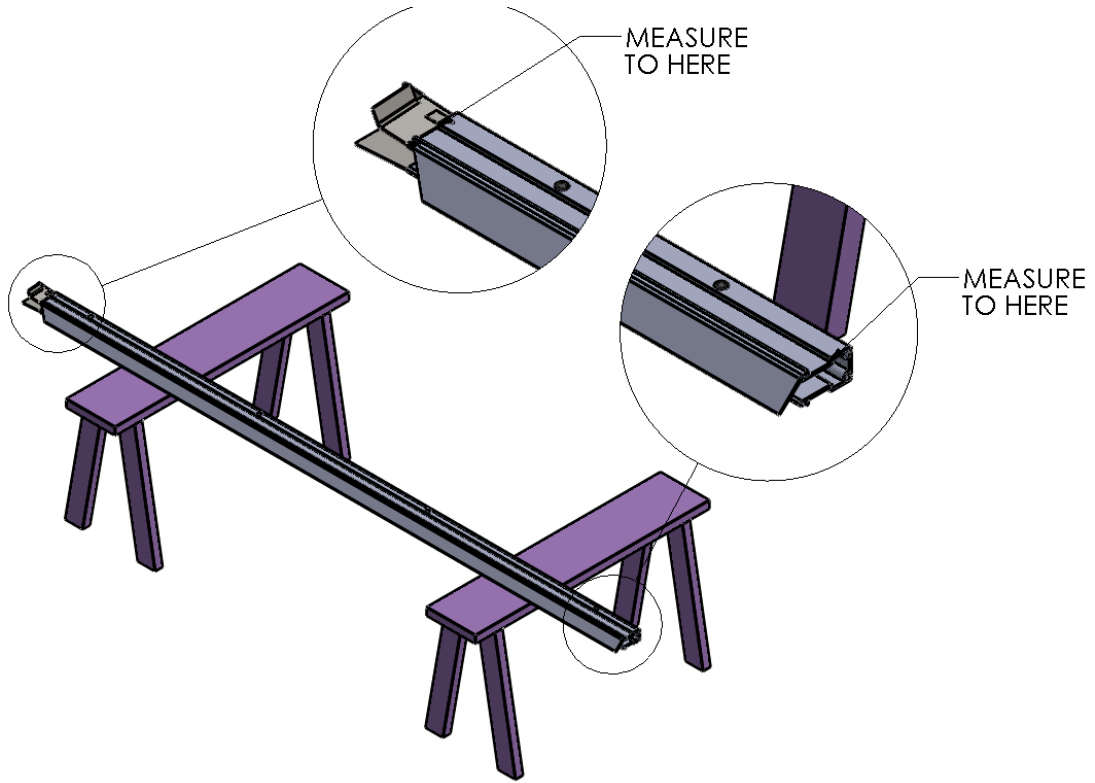

Figure 4 MEASURE TRACK HEIGHT

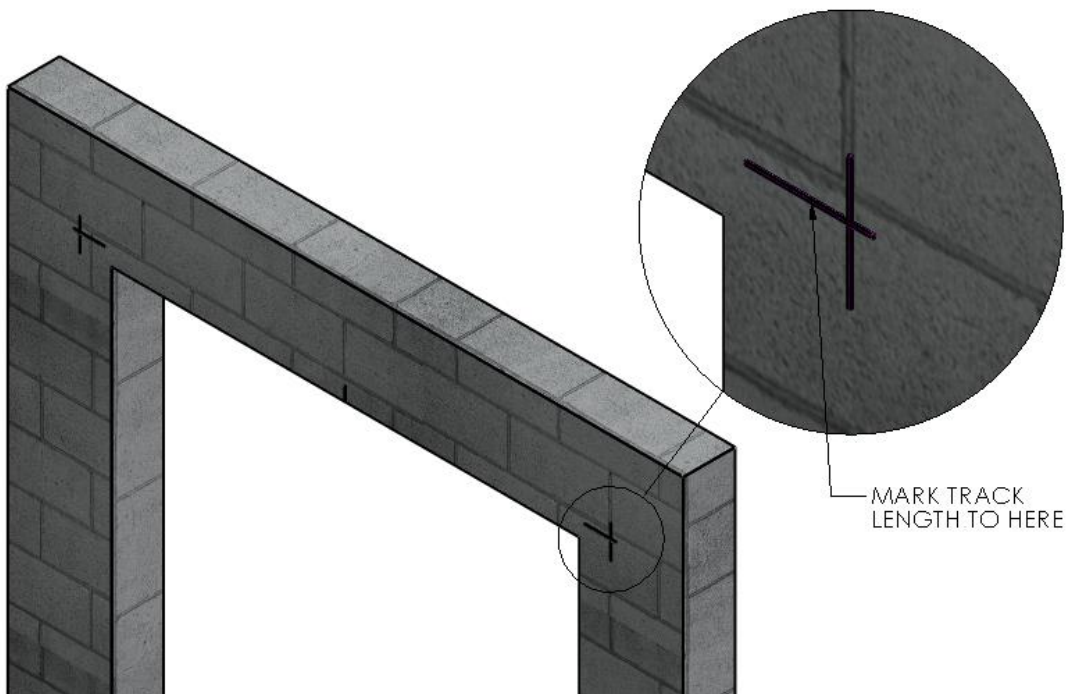

Figure 5 MARK TRACK HEIGHT

RAISE AND ATTACH THE ROLL HEADER ASSEMBLY

8. Using two (2) people, and two ladders at minimum, raise the Roll Header Assembly into place on the wall, and loosely secure with three (3) sets of mounting hardware per side - screws or bolts, adequate to your building/surface material. (Figure 6 MOUNT HEADER ASSEMBLY TO WALL)
9. Check the Header Assembly for level, and fully tighten all six sets of hardware.
10. At this point leave the roll assembly tied off and held in place as it comes.

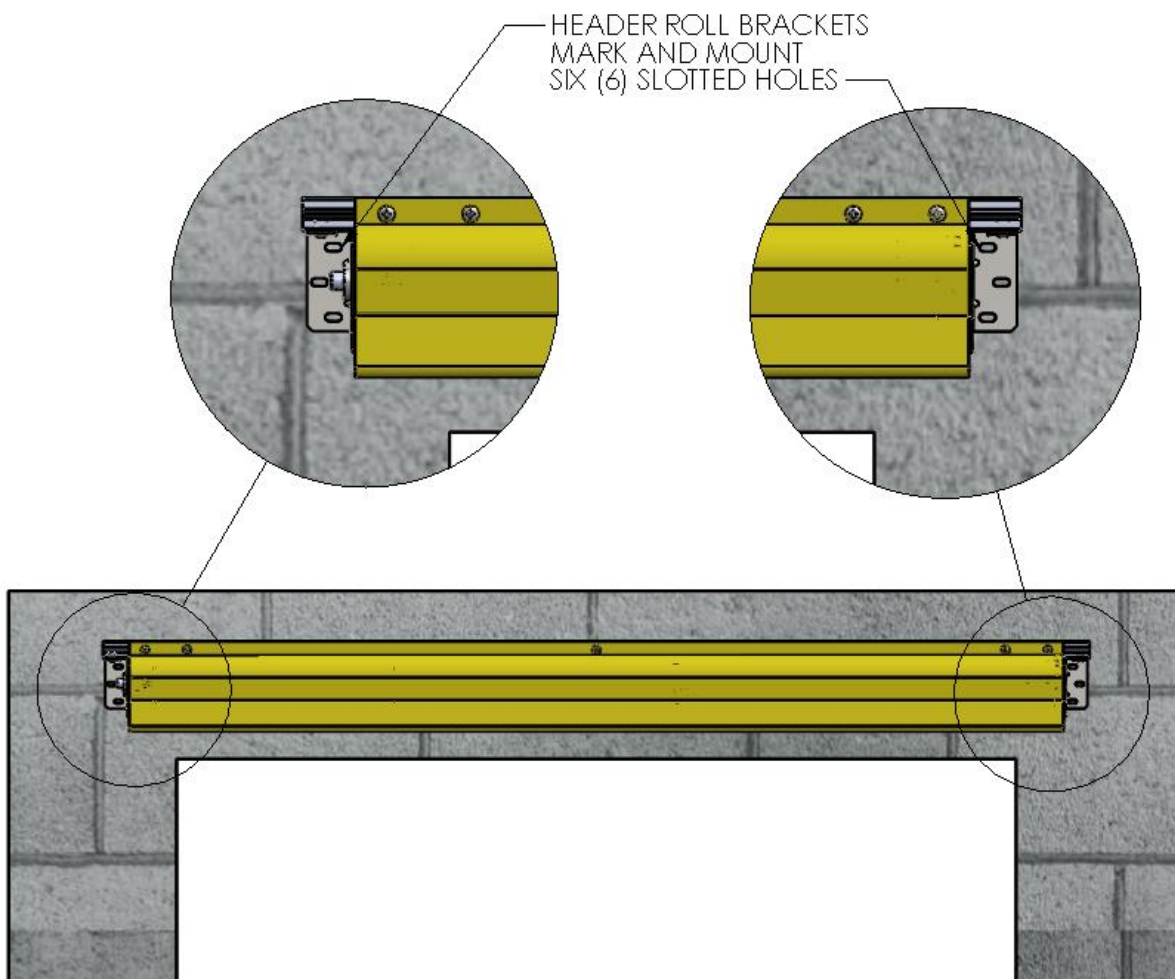

Figure 6 MOUNT HEADER ASSEMBLY TO WALL

MOUNT THE VERTICAL TRACK ASSEMBLIES

1. Starting with either the left or right side, loosely “hang” the Track Assembly by its Transition Bracket Mount hardware. Note that the transition Bracket mounts to the inside of the tab of the Header Assembly Mounting Bracket. It is important to insert the carriage bolt from the inside of the transition and the washer and hex nut on the outside of the assembly as shown. (Figure 7 MOUNT TRACK TO HEADER & MOUNT TRACK TO WALL)
2. With the Track Assembly “hanging” in this position, plumb the Track to make sure it is vertically aligned. Remove the black plastic plugs from the mounting access holes on the Track front. Usually with two people (one holding the track assembly in place), use a marker on the wall to mark their pilot hole locations.
3. Move the Track Assembly off to the side and predrill its mounting holes. Move it back into place and secure it to the wall with appropriate hardware. Before fully tightening hardware, be sure to each track is plumb/vertical. Replace the black plastic plugs in the mounting access holes on the Track front. (Figure 7 MOUNT TRACK TO HEADER & MOUNT TRACK TO WALL)

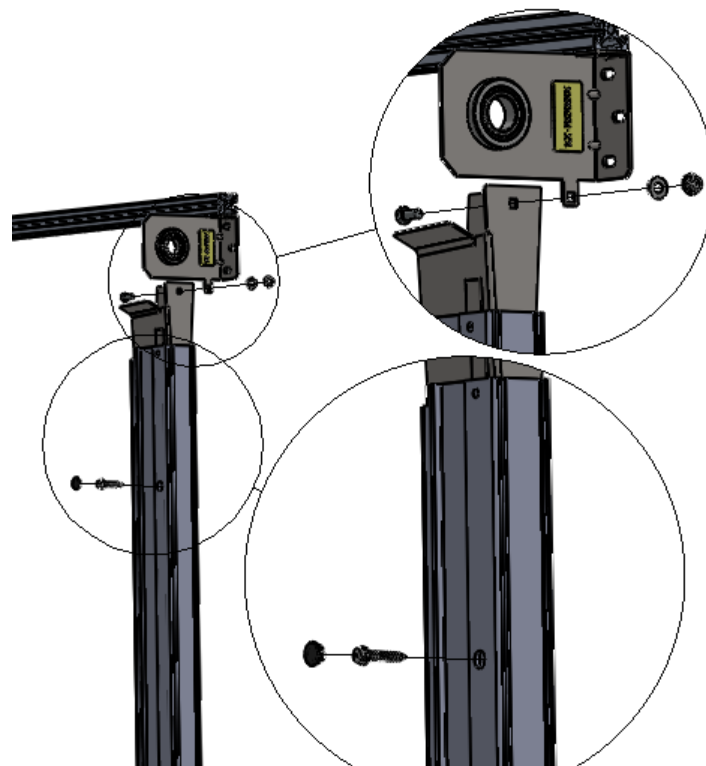

Figure 7 MOUNT TRACK TO HEADER & MOUNT TRACK TO WALL

CHECK ALL MOUNTINGS

1. With everything mounted, take a moment to check all of your hardware, and all of the components for horizontal and vertical alignments.

SECURE PULL STRAP AND ADJUST SPRING OPERATOR

1. Use the Buckle provided to secure the long Pull Strap to the mounting Bracket attached to the Right-Side Track. (Figure 8 SECURE PULL STRAP)
2. Adjust the length to set the upper Stop Point of the Door.

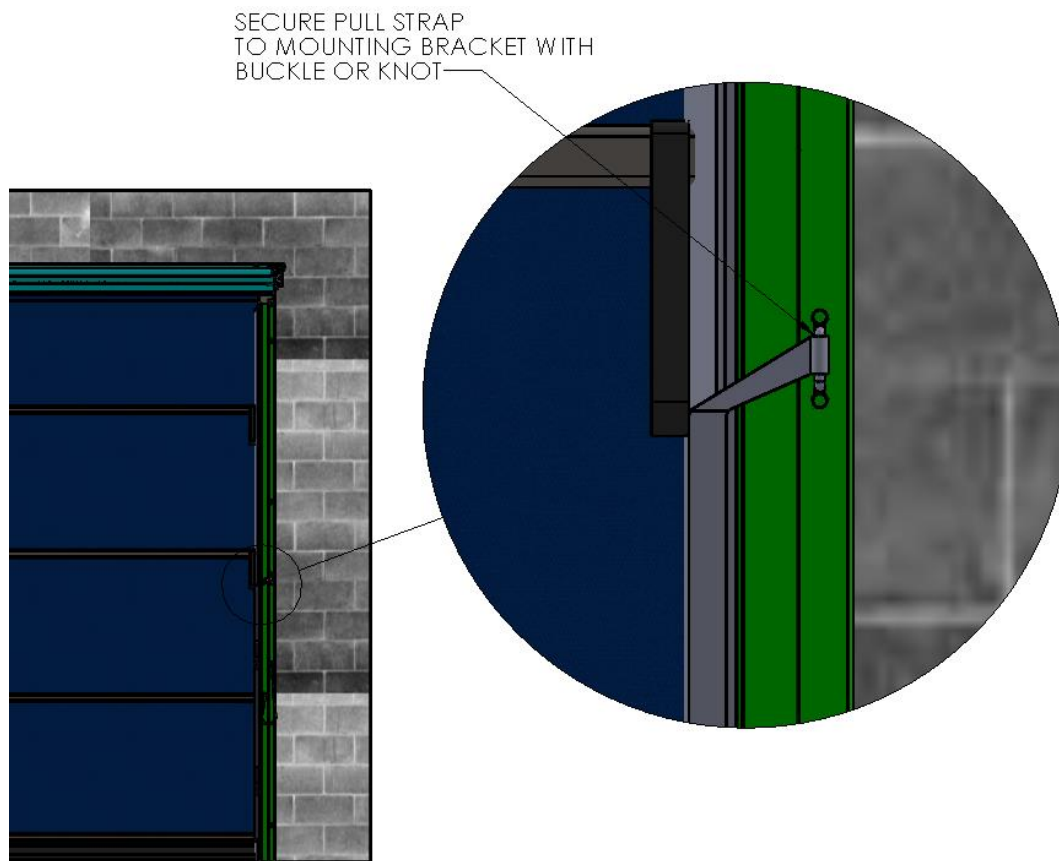

Figure 8 SECURE PULL STRAP

NOTE: Spring tension is maintained either with a 1/2" open-end wrench on the wrench flats, or with the Quick-Release pin.

1. Spring tension is increased/decreased with a two-step process. To increase spring tension, insert the open-end wrench onto the wrench flats, then pull the

Quick-Release pin. Pull the wrench down (CCW) until the pin can be replaced – about a quarter turn. Repeat this two-step process about 8 times equaling about 2 full turns on the spring. (Figure 9 WRENCH FLATS/SPRING TENSIONING PIN)

2. Release the ties on the roll assembly.
3. Use the Pull Straps to pull the door down to the closed position.
4. Release the straps to open the door, and note the upper stop point. Adjust by increasing/decreasing the tension 1 quarter turn, and test again.

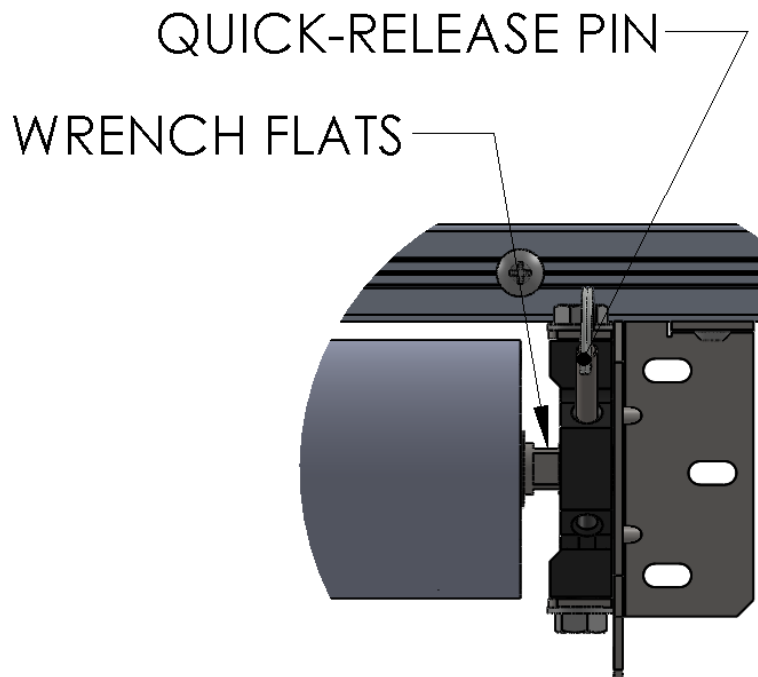

Figure 9 WRENCH FLATS/SPRING TENSIONING PIN

INSTALL THE LOCK PIN LANYARD

NOTE: The top edge of the second lowest Wind Bar of the Door will be where the Lock Pin meets and holds the Door in the closed position. A factory-cut notch is located in the Door Panel, on the right-hand side, to allow the Lock Pin to pass through the Door.

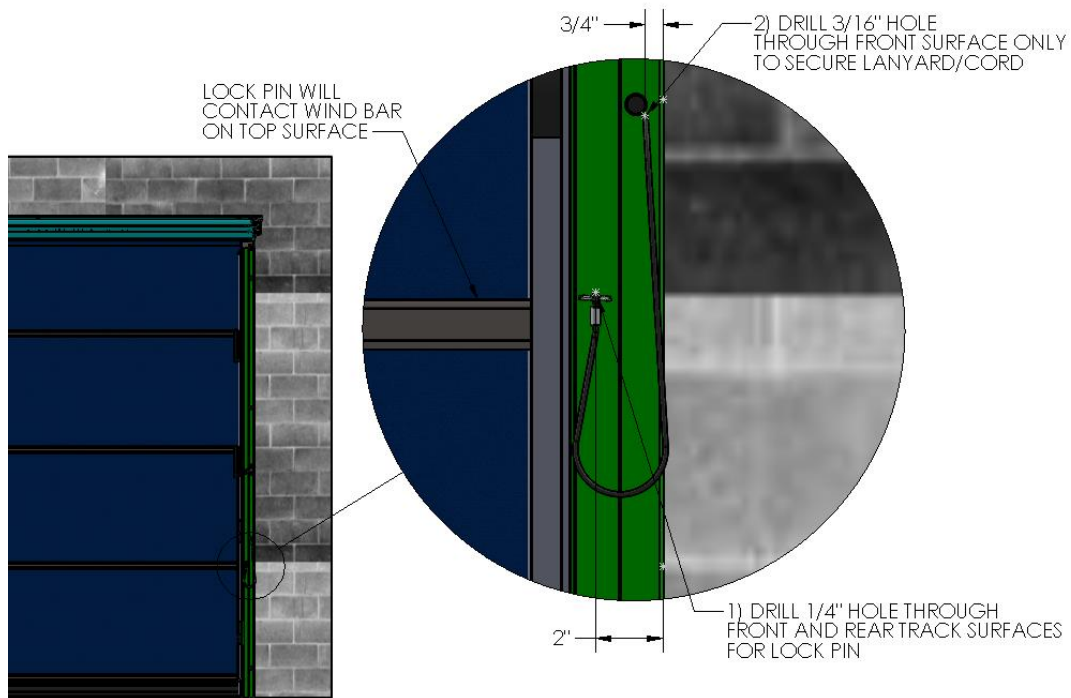

Figure 10 SPRING PIN DETAIL

1. Pull the door down/closed until a satisfactory seal with the floor is achieved
2. Mark the location of the top edge of the second lowest Wind Bar onto the Right-Hand vertical Track.
3. Release the Pull Strap to allow the door to return to the Open Position.
4. Drill a 1/4" Dia. hole through both legs of the track 2" from the right (outside of the track) which intersects your line.
5. Drill a 3/16" hole, a few inches above the 1/4" hole, at about 3/4" from the right (outside of the Track).
6. Insert the Lanyard/cord through this hole, then tie a knot on that end.
7. Pull the Door down to the closed position, then insert the Lock-Pin above the Wind Bar through the front and rear holes.

WARNING

ALL INSTALLATION INSTRUCTIONS MUST BE FOLLOWED, AND CRITICAL ALIGNMENT REQUIREMENTS MUST BE MET.

- ENSURE THAT THE ROLL HEADER ASSEMBLY IS LEVEL, AND THAT THE TRACKS AND BRACKETS ARE ALL PLUMB, AND SQUARE-

OTHERWISE, THE PERFORMANCE AND CONSISTENT OPERATION OF YOUR DOOR WILL BE COMPROMISED.

LIMITED WARRANTY

G1 Bug Screen/Vinyl Doors



Goff's Enterprises, Inc. warrants all G1 bug screen/vinyl doors from failure in normal use due to defects in material or workmanship for a period of **TWO years** from date of purchase with warranty related labor for the first year as approved by Goff's Technical Support Team.

Goff's Enterprises, Inc. may elect to repair or replace defective or damaged goods.

Technical Support Team: 262-746-3374