

## G1 SERIES – LOCK PIN INSTALLATION INSTRUCTIONS

READ THIS MANUAL CAREFULLY. OBSERVE WARNINGS AND PRACTICE CAUTION WHEN INSTALLING, OPERATING, OR MAINTAINING YOUR GOFF'S DOOR ASSEMBLY.

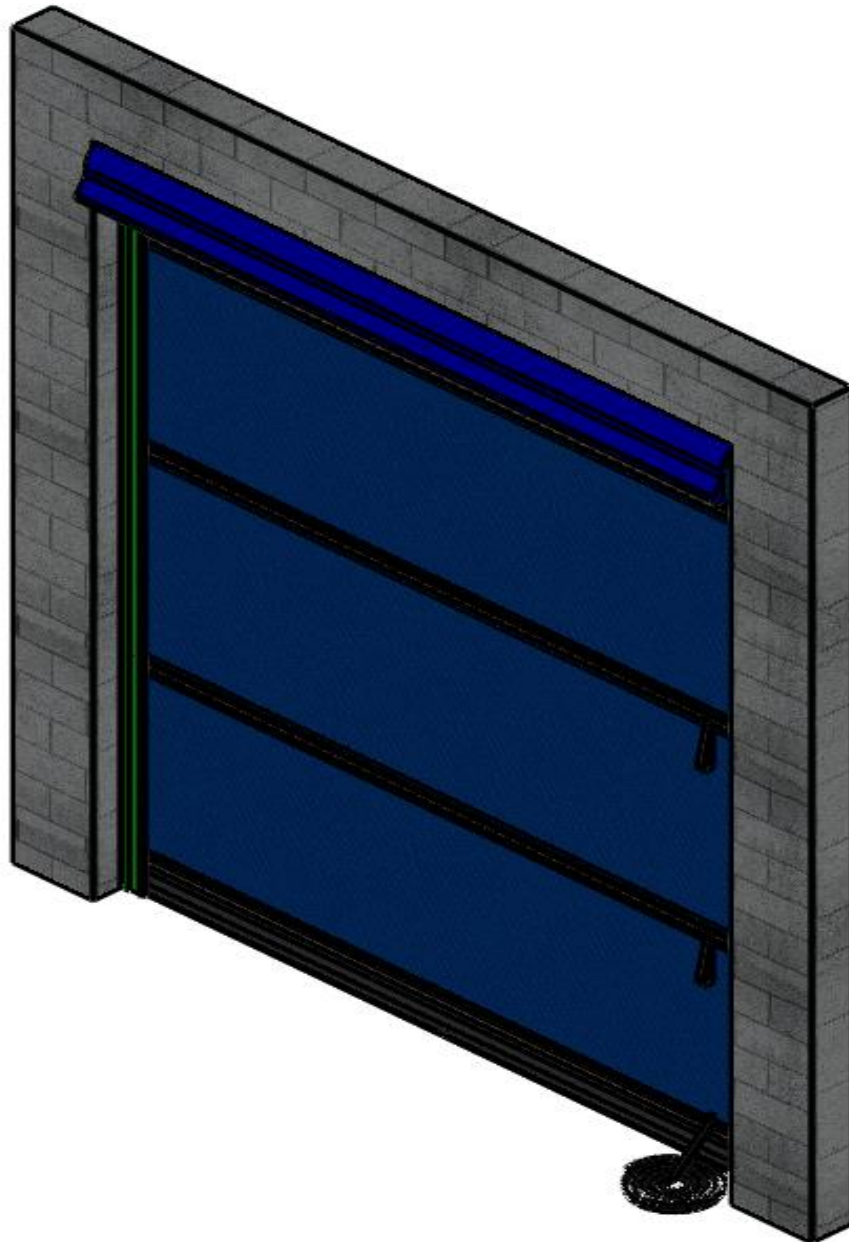

**NOTE:** The top edge of the second lowest Wind Bar of the Door will be where the Lock Pin meets, and holds, the Door in the closed position. A factory-cut notch is located in the Door Panel, on the right-hand side, to allow the Lock Pin to pass through the Door.

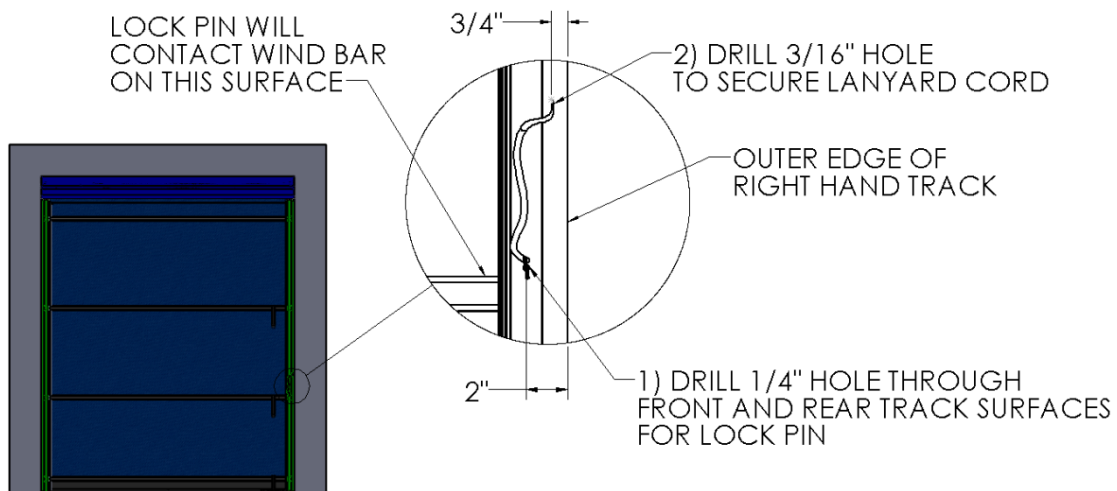

SPRING PIN DETAIL

1. Pull the door down/closed until a satisfactory seal with the floor is achieved
2. Mark the location of the top edge of the second lowest Wind Bar onto the Right-Hand vertical Track.
3. Release the Pull Strap to allow the door to return to the Open Position.
4. Drill a 1/4" Dia. hole through both legs of the track 2" from the right (outside of the track) which intersects your line.
5. Drill a 3/16" hole, a few inches above the 1/4" hole, at about 3/4" from the right (outside of the Track).
6. Insert the Lanyard cord through this hole, and tie a knot on that end.
7. Pull the Door down to the closed position, and insert the Lock-Pin above the Wind Bar through the front and rear holes.

# WARNING

**ALL INSTALLATION INSTRUCTIONS MUST BE FOLLOWED, AND CRITICAL ALIGNMENT REQUIREMENTS MUST BE MET.**

\*\*\*

**- ENSURE THAT THE ROLL HEADER ASSEMBLY IS LEVEL, AND THAT THE TRACKS AND BRACKETS ARE ALL PLUMB, AND SQUARE-**

\*\*\*

**OTHERWISE, THE PERFORMANCE AND CONSISTENT OPERATION OF YOUR DOOR WILL BE COMPROMISED.**

## LIMITED WARRANTY

### G1 Bug Screen/Vinyl Doors



Goff's Enterprises, Inc. warrants all G1 bug screen/vinyl doors from failure in normal use due to defects in material or workmanship for a period of **TWO years** from date of purchase with warranty related labor for the first year as approved by Goff's Technical Support Team.

Goff's Enterprises, Inc. may elect to repair or replace defective or damaged goods.

**Technical Support Team: 262-746-3374**